

Installation Manual



L3

Direct Vent Zero Clearance
Gas Fireplace
natural gas 1800KN
propane gas 1800KP

Installer: Place model/serial number here.

Installer: Leave this manual with the appliance.
Consumer: Retain this manual for future reference.

⚠ WARNING:
FIRE OR EXPLOSION HAZARD
Failure to follow safety warnings exactly could result in serious injury, death, or property damage.

Do not store or use gasoline or other flammable vapors and liquids in the vicinity of this or any other appliance.

WHAT TO DO IF YOU SMELL GAS

- Do not try to light any appliance.

- Do not touch any electrical switch; do not use any phone in your building.
- Leave the building immediately.
- Immediately call your gas supplier from a neighbor's phone. Follow the gas supplier's instructions.
- If you cannot reach your gas supplier, call the fire department.

Installation and service must be performed by a qualified installer, service agency or the gas supplier.

⚠ DANGER



Hot glass will cause burns.

Do not touch glass until cooled.

Never allow children to touch glass.

A barrier designed to reduce the risk of burns from the hot viewing glass is provided with this appliance and must be installed for the protection of children and other at-risk individuals.

This appliance may be installed in an after-market permanently located, manufactured (mobile) home where not prohibited by local codes. This appliance is only for use with the type of gas indicated on the rating plate. This appliance is not convertible for use with other gases, unless a certified kit is used.

INSTALLER: Leave this manual with the appliance.
CONSUMER: Retain this manual for future reference.

Massachusetts:

The piping and final gas connection must be performed by a licensed plumber or gas fitter in the State of Massachusetts. Also, see Carbon Monoxide Detector requirements in this installation manual, page 56.

⚠ WARNING

This product can expose you to chemicals including Benzene, which is known to the State of California to cause cancer and birth defects or other reproductive harm. For more information go to www.P65Warnings.ca.gov.

Note: Natural gas, in its original state, contains Benzene.

This manual contains instructions to install the **ENGINE ONLY**. A trim kit is **REQUIRED** to complete the installation. A barrier screen is provided with the trim kit. **Refer to the manual supplied with the trim for installation.**

This appliance is a domestic room-heating appliance. It must not be used for any other purposes such as drying clothes, etc.

This appliance is suitable for installation in a bedroom or bed sitting room.

Ce guide est disponible en français sur demande.



We recommend a US Certified National Fireplace Institute (NFI) specialist install our gas hearth products.



The information contained in this manual is believed to be correct at the time of printing. Miles Industries Ltd. reserves the right to change or modify any information or specifications without notice. Miles Industries Ltd. grants no warranty, implied or stated, for the installation or maintenance of your heater, and assumes no responsibility for any consequential damage(s).

© Copyright Miles Industries Ltd., 2026 All rights reserved.
Designed and manufactured for Miles Industries Ltd.

Welcome to Valor®

This appliance has been professionally installed by:

Dealer Name: _____

Phone: _____

Please read this manual BEFORE installing and operating this appliance.

Fireplace Safety	4
Specifications	6
Kits & Accessories.....	7
Approved Venting Components	8
Dimensions & Location.....	10
Installation Planning.....	11
Before Installing.....	11
Overview	12
Mantel Clearances	13
Framing.....	15
Wall Finish	18
Material Specifications	18
Non-Combustible Cement Board.....	18
Avoiding Cracking Wall Finishes.....	20
Venting	21
Overview	21
Co-Axial	22
Typical Co-axial Venting Components	22
Venting Chart	23
Restrictor Settings	24
Horizontal Vent Termination	25
Vertical Vent Termination	26
Installation	27
Appliance Preparation	27
Unpack Appliance	27
Fit Standoffs.....	27
Fit Appliance into Framing.....	27
Remove Window	28

HeatShift™ System—if used	29
Remove Convection Baffle	29
Install HeatShift Take-Off Collars to Appliance.....	29
Electrical Wiring	30
Gas Supply.....	32
Liners	34
Fuel Beds	36
Driftwood Log Kit 1800DWKV2.....	36
Decorative Glass Murano Kit 1800DGMV2.....	39
Splitwood Kit 1800SWK.....	41
Birch Log Kit 1800BLK.....	44
Window Re-Installation & Checking	48
Wall Switch	49
Remote Control Pairing.....	51
Checking Operation and Aeration	53
Trim & Barrier Screen.....	54
Wiring Diagram	55
Commonwealth of Massachusetts	56
Appendix A—Lighting Instructions.....	58
Appendix B—Remote Control Operation	59
Appendix C—Wall Switch Operation	66
Appendix D—HeatShift System	67
Appendix E—Spare Parts	88

Fireplace Safety

This manual contains very important information about the safe installation and operation of the fireplace. Read and understand all instructions carefully before installing and operating the fireplace. Failure to follow these instructions may result in possible fire hazard and will void the warranty.

Replacement manuals are available by contacting the Valor Customer Service at 1-800-468-2567, or by visiting valorfireplaces.com.

WARNING: Extremely Hot!

Heat and flammability

- Some parts of the fireplace are extremely hot, particularly the glass windows. Use the barrier screens provided or a gate to reduce the risk of severe burns.
- The glass windows can exceed 500°F at full capacity.
- Always keep the appliance clear and free from combustible materials, gasoline, and other flammable vapors and liquids.
- Be aware of hot wall surfaces! The walls directly above the fireplace can get very hot when the fireplace heats. Although safe, it may reach temperatures in excess of 200°F (93°C) depending on choice of optional accessories. Do not touch!
- Be aware of hot hearth/floor surfaces! Any projections directly around the fireplace can get very hot when the fireplace heats. Although safe, they may reach temperatures in excess of 200°F (93°C) depending on elevation of hearth. Be careful of touching these! Temperature of projection surfaces will be reduced when barrier screens are installed.
- Some materials or items, although safe, may discolor, shrink, warp, crack, peel, and so on because of the heat produced by the fireplace. Avoid placing candles, paintings, photos and other combustible objects sensitive to heat or furniture within 36 inches (0.9 m) around the fireplace.
- Due to its high temperatures, the appliance should be located out of traffic areas and away from furniture and draperies.
- Clothing or flammable material should not be placed on or near the appliance.

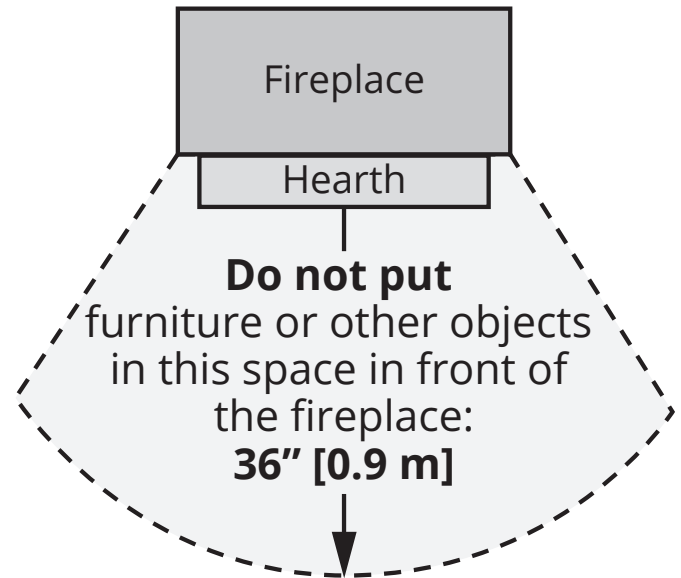

Barrier Screen and Safety

- A barrier designed to reduce the risk of burns from the hot viewing glass is provided with this appliance and shall be installed for the protection of children and other at-risk individuals.
- Children and adults should be alerted to the hazards of high surface temperature and should stay away to avoid burns or clothing ignition.
- Young children should be carefully supervised when they are in the same room as the appliance. Toddlers, young children, and others may be susceptible to accidental contact burns. A physical barrier is recommended if there are at-risk individuals in the house. To restrict access to a fireplace or stove, install an adjustable safety gate to keep toddlers, young children, and other at-risk individuals out of the room and away from hot surfaces.
- Any safety screen, guard, or barrier removed for servicing an appliance must be replaced prior to operating the appliance.

Fireplace Safety

Glass windows

WARNING

Do not operate this appliance with the glass front removed, cracked, or broken.

Do not strike or slam the glass front.

Replacement of the glass front should be performed by a licensed or qualified service person.

- The glass front assemblies must be in place and sealed before the unit can be placed into safe operation.
- The glass front assemblies must only be replaced as complete units, as supplied by the fireplace manufacturer. No substitute material may be used.
- Do not use abrasive cleaners on the glass front assemblies. Do not attempt to clean the glass when it is hot.

Venting

- This unit must be used with a vent system as described in this manual. No other vent system or components may be used.
- Never obstruct the flow of combustion and ventilation air. Keep the front of the appliance clear of all obstacles and materials for servicing and proper operation.
- This gas fireplace and vent assembly must be vented directly to the outside and must never be attached to a chimney serving a separate solid fuel burning appliance. Each gas appliance must use a separate vent system. Common vent systems are prohibited.

Intended use

- This appliance is designed and approved as a supplemental heater and provides the potential for most energy conservation when used while attended. The use of an alternate primary heat source is advisable.
- This unit is not for use with solid fuel.
- Do not use this heater as a temporary source of heat during construction.

Installation and Servicing

- Installation and repair should be done by a qualified service person. The appliance should be inspected before use and at least annually by a professional service person. More frequent cleaning might be required due to excessive lint from carpeting, bedding material, et cetera. It is imperative that control compartments, burners, and circulating air passageways of the appliance be kept clean.
- Do not use this appliance if any part has been under water. Immediately call a qualified service technician to inspect the appliance and to replace any part of the control system and any gas control that has been under water.

WARNING

Ceiling outlet
Front outlet
Side outlets

**HeatShift System:
Do not cover
or place items
in front of or
above outlet(s)!**

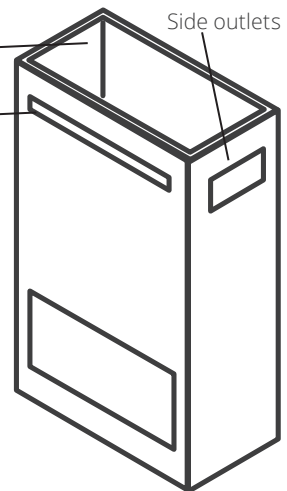

Specifications

Approval & Codes

This appliance is certified to ANSI Z21.88 / CSA 2.33 American National Standard / CSA Standard for Vented Gas Fireplace Heaters for use in Canada and USA, and to CGA 2.17-91 High Altitude Standard in Canada. This appliance is for direct vent installations.

This appliance complies with CSA P.4.1-15 Testing method for measuring annual fireplace efficiencies.

The installation must conform to local codes or, in the absence of local codes, with the National Fuel Gas Code, ANSI Z223.1/NFPA 54 or the Natural Gas and Propane Installation Code CAN/CGA-B149.1. Only qualified licensed or trained personnel should install this appliance.

This appliance must be electrically grounded in accordance with local codes, or, in the absence of local codes, with the National Electrical Code, ANSI/NFPA 70 or the Canadian Electrical Code, CSA C22.1.

Ratings

Model	1800KN	1800KP
Gas	Natural	Propane
Altitude (Ft.)*	0-4,500 feet*	
Input Maximum (Btu/h)	42,000	42,000
Input Minimum (Btu/h)	23,000	23,000
Manifold Pressure (in w.c.)	3.5"	10"
Minimum Supply Pressure (in w.c.)	5"	11"
Maximum Supply Pressure (in w.c.)	10"	14"
Main Burner Injector Marking	DMS#30	DMS#48
Pilot Injector Marking	51	30
Min. Rate Bypass Screw	260	160

*High Altitude Installations

Input ratings are shown in BTU per hour and are certified without deration for elevations up to 4,500 feet (1,370 m) above sea level.

For elevations above 4,500 feet (1,370 m) in USA, installations must be in accordance with the current ANSI Z223.1 and/or local codes having jurisdiction. Heating value of gas in some areas is reduced to compensate for elevation—consult your local gas utility to confirm.

For installations at elevations above 4,500 feet (1,370 m) in Canada, please consult provincial and/or local authorities having jurisdiction.

Supply Gas

Heater engine 1800KN uses natural gas.
Heater engine 1800KP uses propane gas.

The supply pressure must be between the limits shown in the *Ratings* section.

The supply connection is 3/8" NPT male and located on the left hand side of the firebox. A shut-off valve (not supplied) is required on the supply line to isolate the unit during service. See *Gas Supply Installation* section for details.

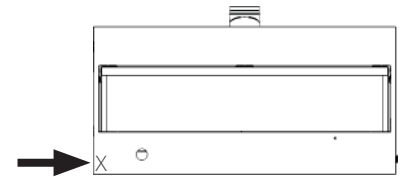

Conversion Kits

The 1800K are supplied as natural gas or propane gas and are field convertible between fuels. See instructions packaged with the conversion kits for further information.

Electrical

The 1800K are designed to run on battery power and do not require an electrical power source to operate as a heater. However, they require electrical power to operate optional 1595CFKV2 Circulating Fan Kit, GV60WIFI WiFi Kit or 1270RBK Remote Blower Kit.

HeatShift™ System

The 1800K are designed to allow the installation of the optional HeatShift System, a convection system that redistributes the warm air flow away from the fireplace opening to a more desirable location using natural convection, without use of a fan.

The warm air flow may be relocated to a position higher up the wall, out the sidewalls, or even to another room. The result is much cooler wall temperatures above the fireplace opening for locating televisions, artwork, etc.

Please note that the framing and mantel clearances are affected by the installation of the HeatShift System. Refer "Appendix D—HeatShift System" on page 67 for more information.

Outdoor Conversion Kit

The 1800K models are supplied standard for indoor applications and may be adapted for installation in specific "outdoor" applications protected from weather as defined in the GV60CKO outdoor conversion kit manual.

Kits & Accessories

Required Kits Information accurate at the time of printing and subject to change without notice.

Fuel Beds (choose one)		
1800DWKV2	Driftwood Kit	
1800DGMV2	Decorative Glass Murano Kit	
1800SWK	Splitwood Kit	
1800BLK	Birch Logs Kit	
Liners Panels (choose one)		
1815FBL	Fluted Black Liners	
1825RGL	Reflective Glass Liners (requires 1725RGL-3 Glass Retainer Kit)	
1860PBL	Plain Black Liners	
Trims (choose one)		Barrier Screen
1830CIK*	Clean Install Kit - Fine Mesh - REQUIRES HeatShift	4007940
1850LSB	Linear 3-1/2" Surrounds	4005460
1875LFB	Linear 1" Finishing Trim Black	4005413
Approved Venting Components		
See following pages for list of Approved Venting Components.		

Optional Accessories Information accurate at the time of printing and subject to change without notice.

Gas Conversion Kits	
1800KNGK	Conversion to natural gas
1800KPGK	Conversion to propane gas
Other Accessories	
GV60WIFI**	WiFi kits - REQUIRES GV60VM Kit
GV60CKO**	Outdoor Fireplace Conversion Kit
1595CFKV2**	Circulating Fan Kit - REQUIRES GV60VM Kit
1270RBK**	HeatSplit Remote Blower Kit
LDK	HeatShift System Kits (gravity flow) - MANDATORY with 1830CIK
Hearth Gate	Hearth gates such as Cardinal's VersaGate are available at retail stores carrying safety products for children.

WARNING

*** HeatShift System MUST be installed on this appliance when using 1830CIK—Clean Installation Kit!**

WARNING

**** NO ELECTRICAL CONNECTION ALLOWED for any outdoor installation!**

Approved Venting Components

Approved Direct Vent Suppliers - Valor Models 1800							
Venting Parts Description		Venting Parts Code / availability by Manufacturer					
		DURA-VENT	SELKIRK	ICC EXCEL DIRECT	MILES INDUSTRIES	BDM	
Termination Caps	Horizontal	Standard Co-axial	46DVA-HC	4DT-AHC	TM-4HT	658DVK2	DVR6-HC
		Deluxe Co-axial	—	—	TM-4RHT	—	DVR6-HCP
		High Wind Co-axial	—	—	—	—	—
	Vertical	Standard Co-axial	46DVA-VC	4DT-VT	—	—	DVR6-VCH DVR6-VCSB —
		High Wind Co-axial	46DVA-VCH	—	TM-4SVT	—	—
		Extended Co-axial	46DVA-VCE	—	—	—	—
		Snorkel, 14" Rise	46DVA-SNK14	4DT-ST14	TM-4ST14	—	DVR6-SNK14
	Snorkel, 36" Rise	46DVA-SNK36	4DT-ST36	TM-4ST36	—	DVR6-SNK36	
Adjustable Pipe Length and Pipe Extensions 4" x 6-5/8"	Galvanized or Black	46DVA-08A 46DVA-08AB (3" to 7")	—	—	—	DVR6-08A DVR6-08AB	
	Galvanized or Black	46DVA-16A 46DVA-16AB (3" to 14-1/2")	ADT-AJ12 ADT-AJ12B (4" to 10")	TC-4DLS1 TC-4DLS1B	—	DVR6-16A DVR6-16AB	
	Galvanized or Black	46DVA-17TA 46DVA-17TAB (11" to 17")	ADT-TL14 ADT-TL14B (14" to 22")	TC-4DLS2 TC-4DLS2B (1-7/8" – 21")	—	—	
	Galvanized or Black	46DVA-24TA 46DVA-24TAB (17" to 24")	ADT-TL38 ADT-TL38B (38" to 70")	TC-4DLA30 TC-4DLA30B (16.5" – 29")	—	—	
	Coaxial Flex	46DVA-36FF 46DVA-60FF 46DVA-120FF	—	—	—	—	
DV Elbows	30°	Galvanized	46DVA-E30	—	—	—	
		Galvanized	46DVA-E45 (swivel)	4DT-EL45	TE-4DE45	—	DVR6-E45
	45°	Black	46DVA-E45B (swivel)	4DT-EL45(B)	TE-4DE45B	—	DVR6-E45B
		Galvanized	46DVA-E60	—	—	—	—
	90°	Galvanized	46DVA-E90 (swivel)	4DT-EL90	TE-4DE90	—	DVR6-E90
		Black	46DAV-E90B (swivel)	4DT-EL90(B)	TE-4DE90B	—	DVR6-E90B

Approved Venting Components

Venting Parts Description			Venting Parts Code / availability by Manufacturer					
			DURA-VENT	SELKIRK	ICC EXCEL DIRECT	MILES INDUSTRIES	BDM	
Pipes 4" x 6 5/8" (ID x OD)	6" long	Galvanized	46DVA-06	4DT-06	TC-4DL6	—	DVR6-06	
		Black	46DVA-06B	4DT-06(B)	TC-4DL6B		DVR6-06B	
	7" long	Galvanized	—	—	—	—	—	
		Black	—	—	—		—	
	9" long	Galvanized	46DVA-09	4DT-09	TC-4DL9	—	DVR6-09	
		Black	46DVA-09B	4DT-09(B)	TC-4DL9B		DVR6-09B	
	12" long	Galvanized	46DVA-12	4DT-12	TC-4DL1	—	DVR6-12	
		Black	46DVA-12B	4DT-12(B)	TC-4DL1B		DVR6-12B	
	18" long	Galvanized	46DVA-18	4DT-18	—	—	DVR6-18	
		Black	46DVA-18B	4DT-18(B)			DVR6-18B	
	24" long	Galvanized	46DVA-24	4DT-24	TC-4DL2	—	DVR6-24	
		Black	46DVA-24B	4DT-24(B)	TC-4DL2B		DVR6-24B	
	36" long	Galvanized	46DVA-36	4DT-36	TC-4DL3	—	DVR6-36	
		Black	46DVA-36B	4DT-36(B)	TC-4DL3B		DVR6-36B	
	48" long	Galvanized	46DVA-48	4DT-48	TC-4DL4	—	DVR6-48	
		Black	46DVA-48B	4DT-48(B)	TC-4DL4B		DVR6-48B	
	Flashings	Roof Flashing 0/12-6/12		46DVA-F6	4DT-AF6	TF-4FA	—	DVR6-AF012
		Roof Flashing 7/12-12/12		46DVA-F12	4DT-AF12	TF-4FB	—	DVR6-AF712
Flat Roof Flashing		46DVA-FF	—	TF-4F	—	DVR6-TCF		
Masonry Flashing		—	—	TF-4MF	—	—		
New Siding Flashing		—	—	—	658NSFK	—		
Various Venting System Parts	Wall Thimble		46DVA-WT	4DT-WT1	TM-4WT	—	DVR6-WTU	
	Storm Collar		46DVA-SC	4DT-SC	TM-SC	—	DVT68-SC	
	Decorative Plate		46DVA-DC	—	TM-4TR TM-4TP	—	DVR6-DC	
	Support Box	Cathedral Ceiling	46DVA-CS	4DT-CCS	TM-4SS	—	DVR6-CS	
		Regular Ceiling	—	4DT-CS	—	—	—	
	Ceiling Firestop		46DVA-FS	4DT-FS	TM-4RDS TM-CS	—	DVR6-CFS	
	Attic Radiation Shield / Firestop		46DVA-IS	4DT-AIS	TM-4AS	—	DVR6-AIS	
	Wall Strap		46DVA-WS	4DT-WSB	TM-WS	—	DVR6-WS	
	Vinyl Siding Standoff		46DVA-VSS	4DT-VSS (before siding) 4DT-VSSB (after siding)	TM-VSS	—	DVR6-VSS	
	Elbow Strap / Offset Support		46DVA-ES	4DT-OS	TM-OS	—	DVR6-ES	
Terminal Guard		46DVA-WG	—	TM-HTS TM-RHTS	845TG 658TG	DVR6-SHRD		

- Notes:**
1. Follow instructions supplied with each manufacturer's components.
 2. Unless otherwise specified, all the parts and assemblies from the above table are to be used with 4" x 6-5/8" pipes.
 3. Do not mix components from different vent manufacturers except Miles Industries' which have been tested with other manufacturers'.

Dimensions & Location

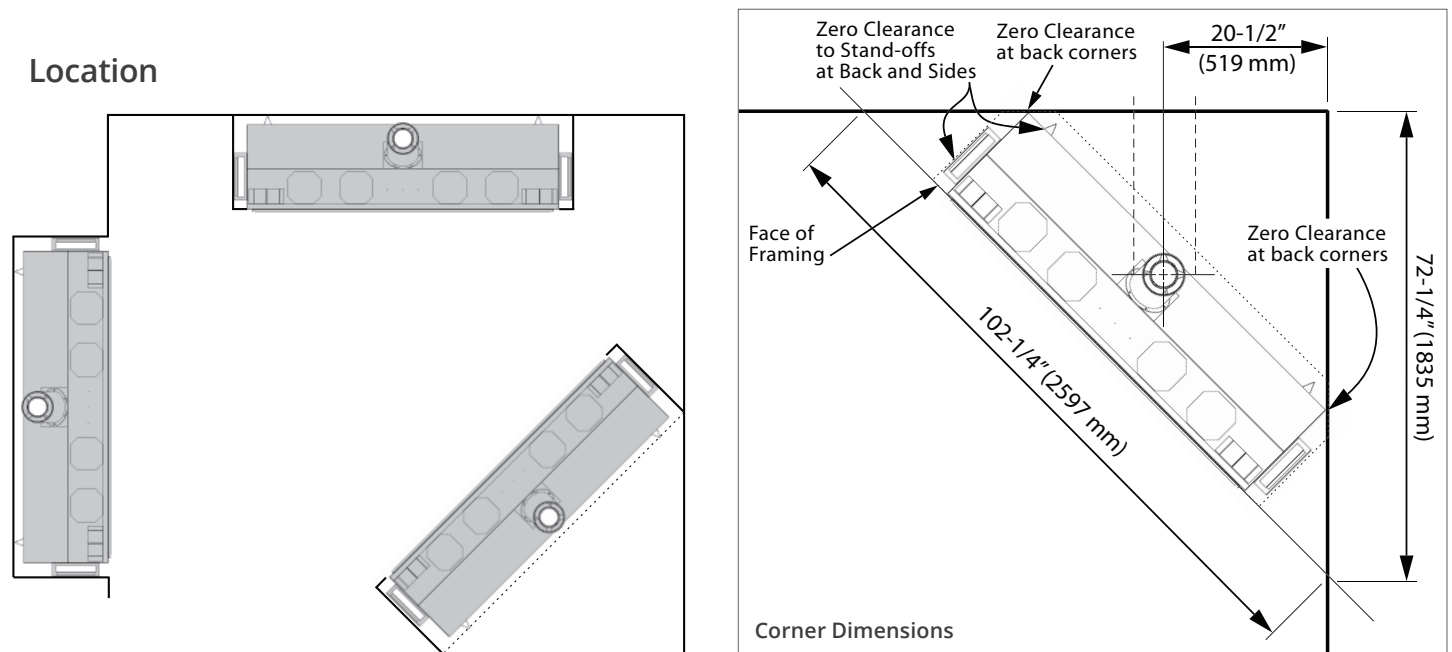
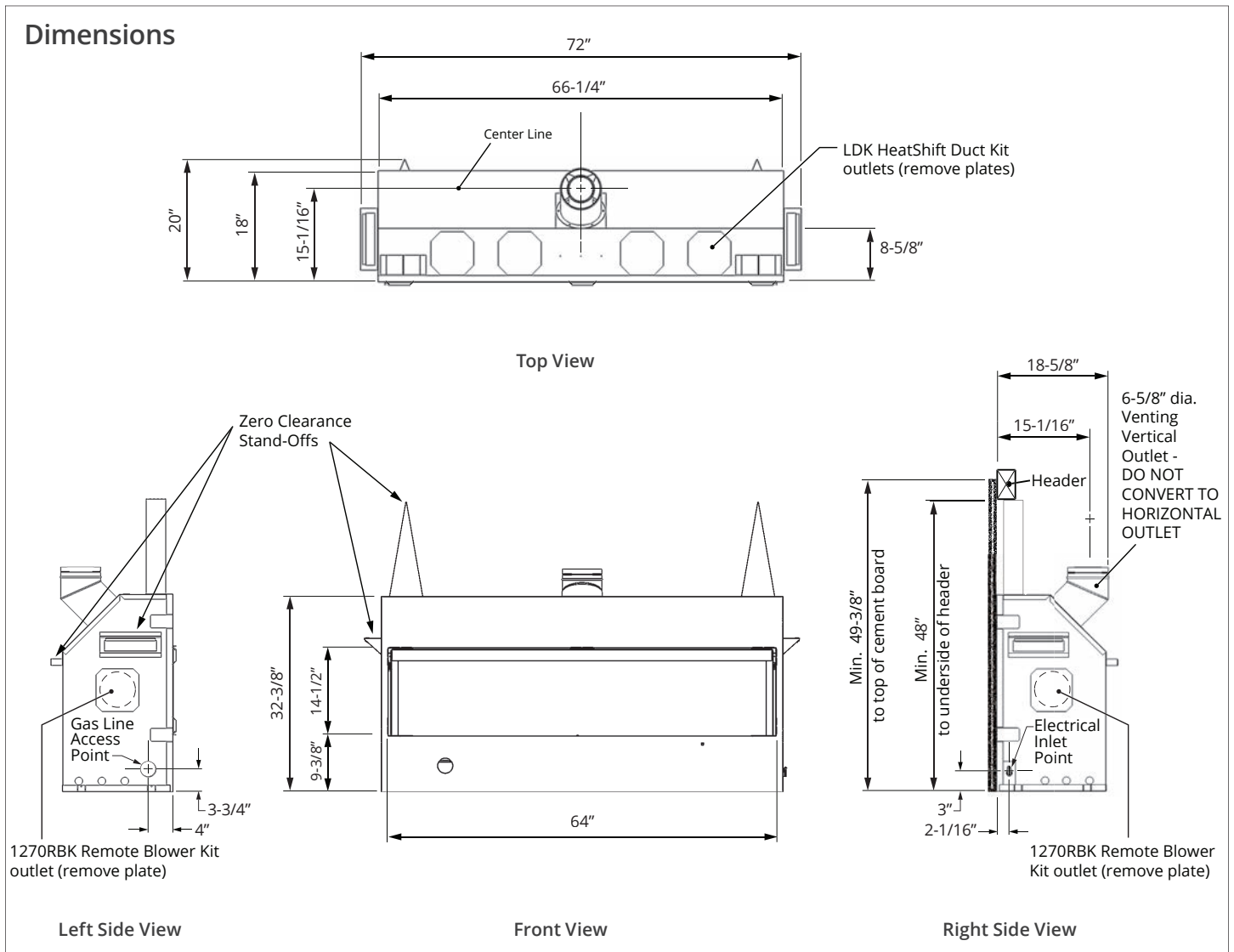

Installation Planning

Before Installing

Caution

Only qualified, licensed, or trained personnel should install this appliance.

1. YOU NEED TO KNOW FROM THE HOMEOWNER:
 - Will optional HeatShift System* be used;
 - Height of appliance and shelf, if used;
 - Thickness and type of wall finish around appliance;
 - Trim used*;
 - Other optional accessories used (if any);
 - Venting configuration.
2. Unpack the appliance, removing all items packed inside and around it. Recycle the packaging.
3. Check that you have everything, using the Pack Content sheet. Also, check that you have:
 - Fuel bed (packed separately);
 - Liner panels (packed separately);
 - Remote Battery and Wall Switch Kit;
 - HeatShift System components (if used);
 - Gas conversion kit (if necessary);
 - Venting accessories;
 - Electrical accessories (if used).**
4. Carefully read the Installer's Checklist included with the fireplace for the installation sequence.

WARNING

***HeatShift System MUST be installed on this appliance when using 1830CIK—Clean Installation Kit!**

WARNING

**** NO ELECTRICAL CONNECTION ALLOWED for any outdoor installation!**

Installation Planning

Overview

Note: This appliance may be installed in outdoor, weather protected environments as defined in the GV60CKO Outdoor Conversion Kit instruction manual.

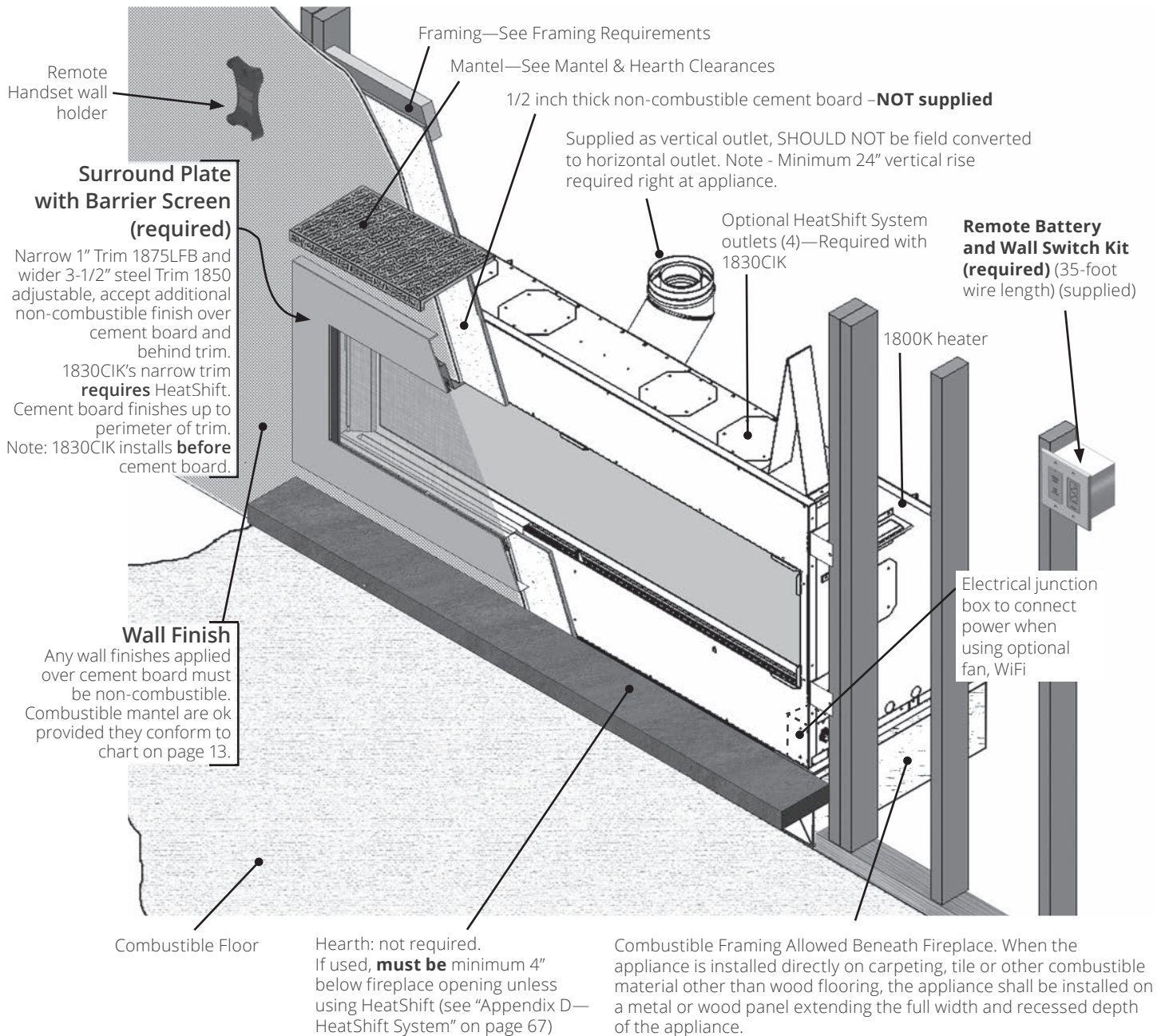

⚠ WARNING

Some materials or items, although safe, may discolor, shrink, warp, crack, peel, and so on because of the heat produced by the fireplace. Avoid placing candles, paintings, photos, and other items sensitive to heat around the fireplace.

⚠ WARNING

HOT WALL SURFACES! The wall directly above the fireplace is constructed of non-combustible materials and, although safe, it may reach temperatures in excess of 200°F (93°C) depending on choice of trims. Do not touch. Finish wall using materials suitable for these temperatures.

Installation Planning

Mantel Clearances

Combustible Mantel—Left Side View

NOTE

Use for the optional HeatShift System affects mantel and hearth clearances. See HeatShift section in Appendix D of this manual.

WARNING

HeatShift System **MUST** be installed on this appliance when using 1830CIK—Clean Installation Kit!

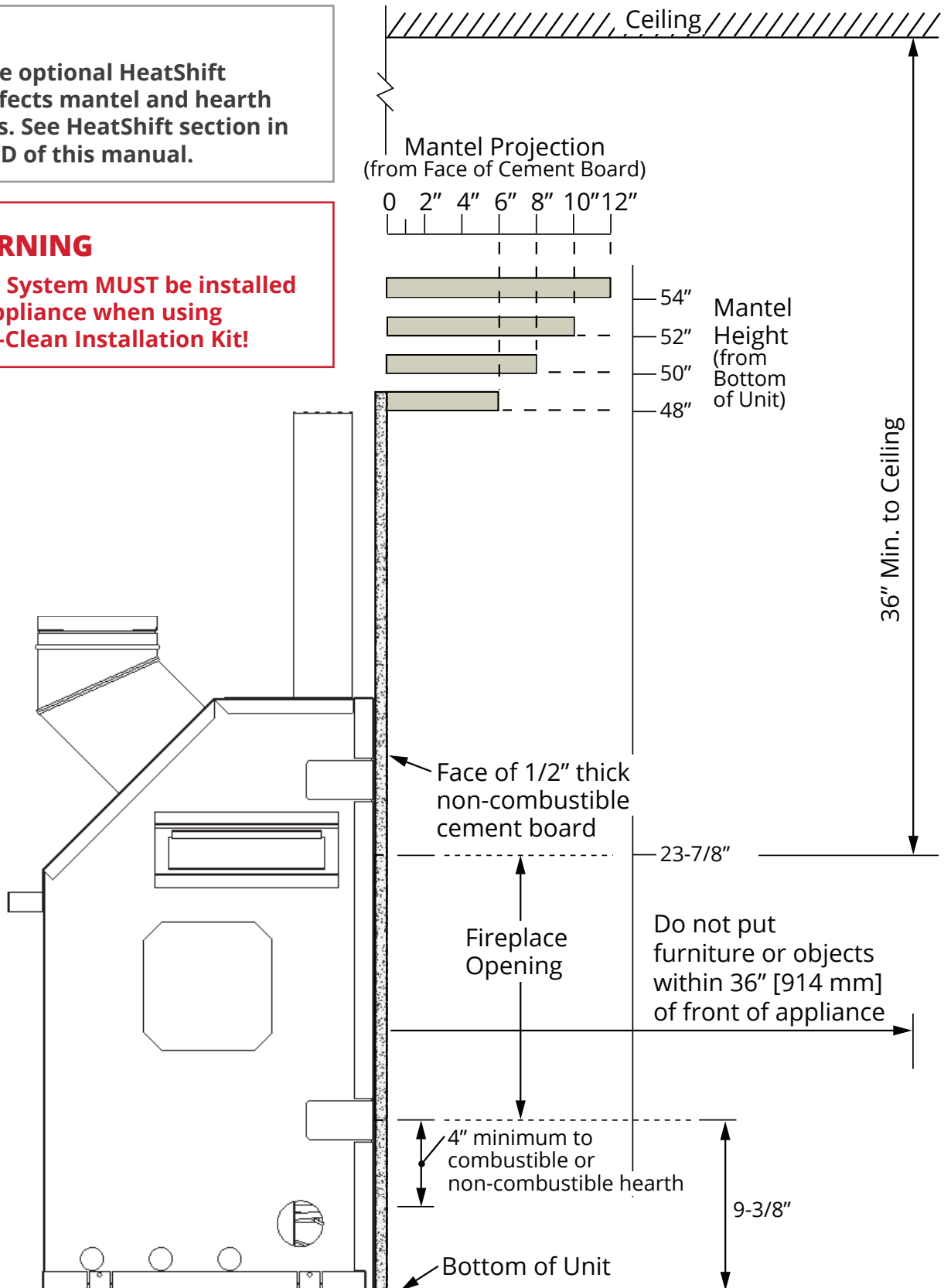

Installation Planning

Mantel Clearances

Combustible Sidewall / Mantel Leg—Top View

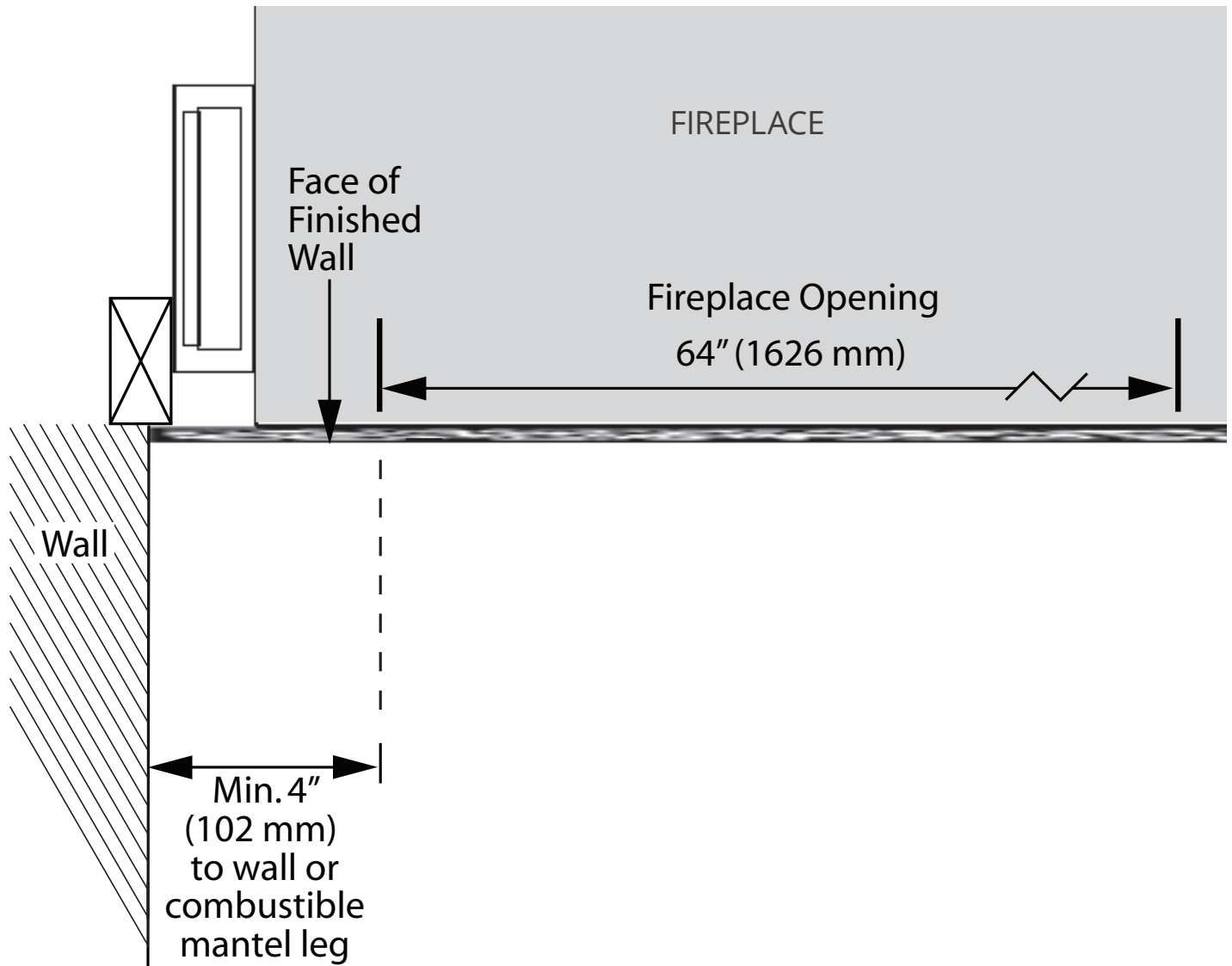

Installation Planning

Framing

Framing Dimensions

NOTE

Use of the optional HeatShift System affects mantel and hearth clearances. See HeatShift section in Appendix D of this manual.

WARNING

HeatShift System **MUST** be installed on this appliance when using 1830CIK—Clean Installation Kit!

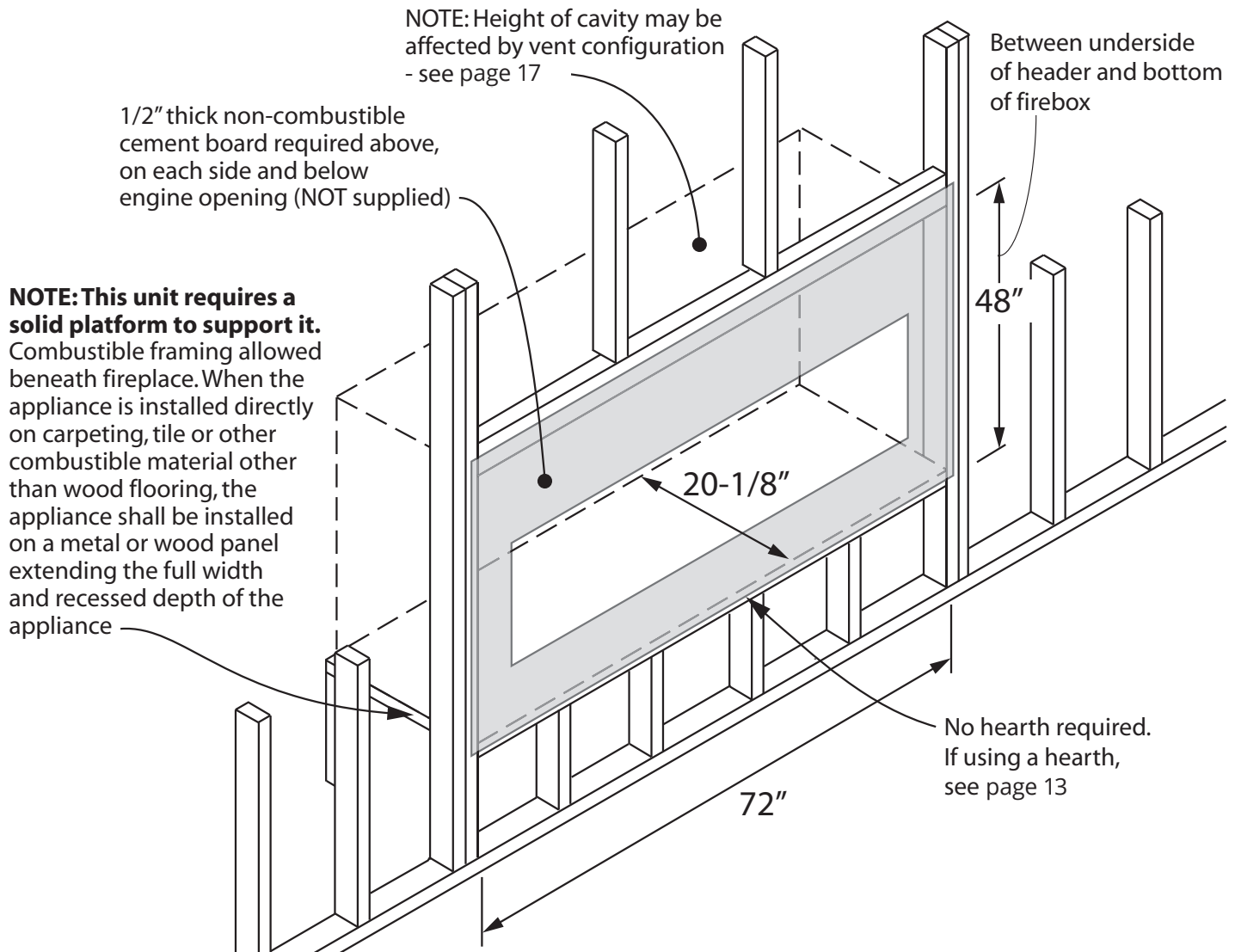

Installation Planning

Framing

Framing with Partial Shelf—Top Outlet

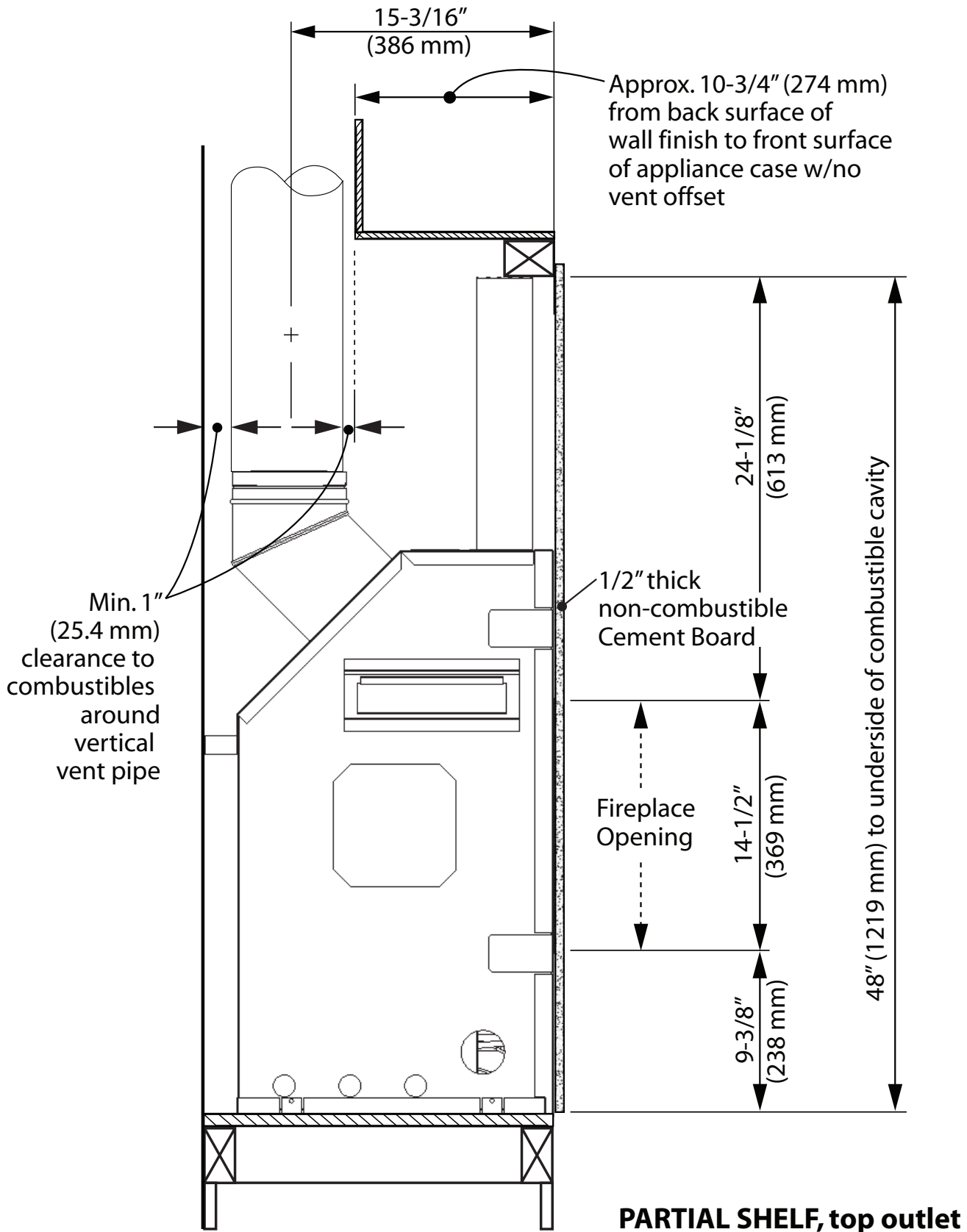

Installation Planning

Framing

Venting Considerations—Vertical Takeoff

*Notes—ALL venting considerations

- Dimensions of venting are based on using Dura-Vent elbows. Elbow curve radius dimensions will vary when using other brands. In general, other brands have slightly bigger radius.
- Minimum 24 inches vertical pipe section required right at unit. Refer to venting chart on page 30 for allowable horizontal runs.

- 3 inches clearance to combustibles required above horizontal pipe. Slope horizontal pipe upwards 1/4 inch per foot. 1 inch clearance required around sides and bottom of horizontal pipe and around vertical pipe.
- When calculating effective pipe lengths subtract approximately 1-1/2 inch for pipe joint - for example, a 12 inches pipe section will add approximately 10-1/2 inches overall.

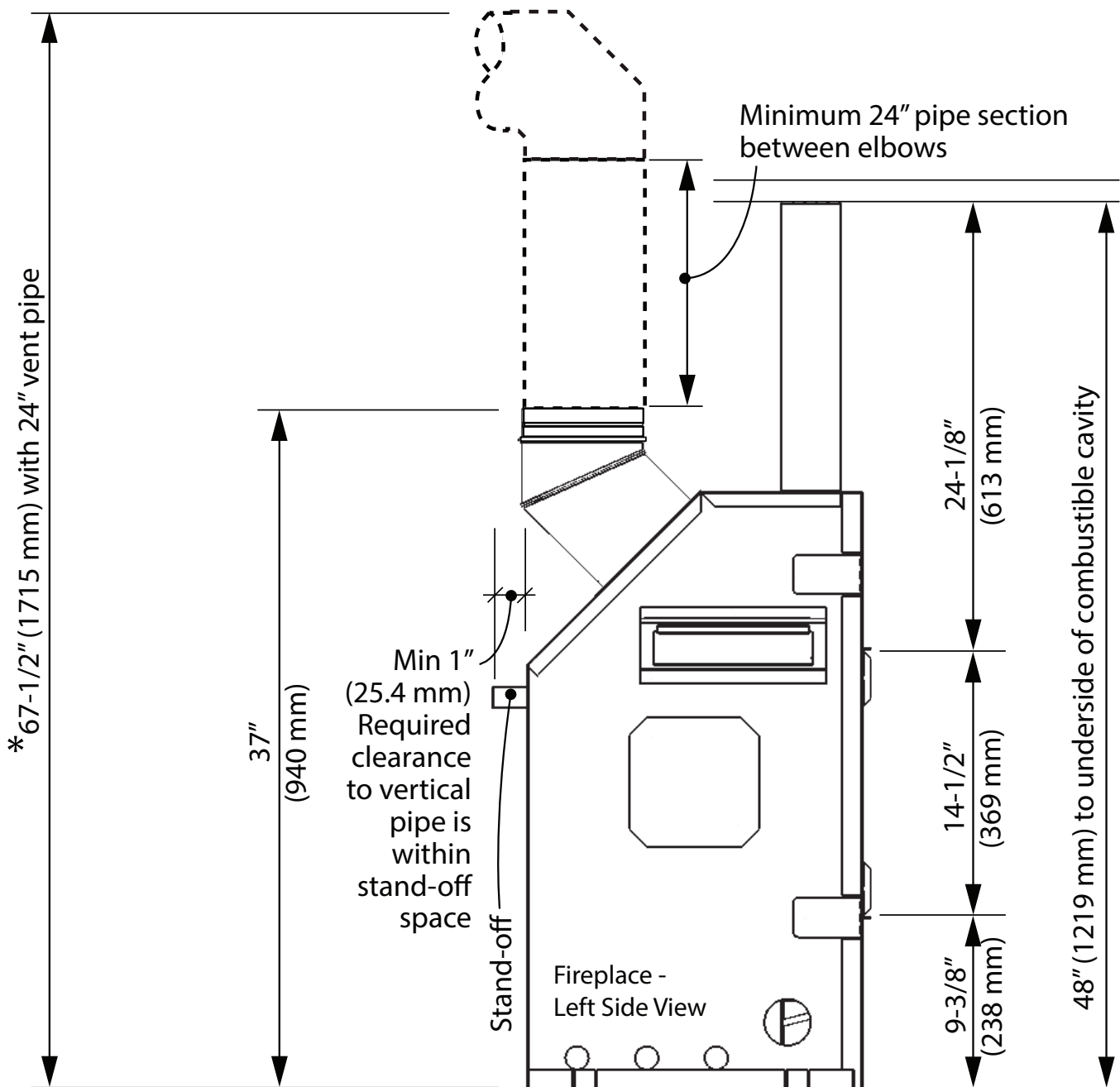

Installation Planning

Wall Finish

Material Specifications

Non-Combustible

Material which will not ignite and burn. Such materials are those consisting entirely of steel, iron, brick, tile, concrete, slate, glass or plasters, or any combination thereof.

Materials that are reported as passing ASTM E 136, Standard Test Method for Behavior of Materials in a Vertical Tube Furnace at 750°C shall be considered non-combustible materials.

Combustible

Materials made of or surfaced with wood, compressed paper, plant fibers, plastics, or other material that can ignite and burn, whether flame proofed or not, or plastered or unplastered shall be considered combustible materials.

Non-Combustible Cement Board

The L3 Linear fireplace requires a 1/2" (13 mm) thick non-combustible cement board to be used as a wall surface immediately surrounding the unit's opening—see diagram for minimum coverage.

Extending the cement board well beyond the minimum shown will help avoid cracking due to differential expansion of materials.

Pre-drill cement board with oversized holes and do not over-tighten screws to avoid cracking due to heat expansion.

Standard gypsum wall board may be used beyond the perimeter of the cement board.

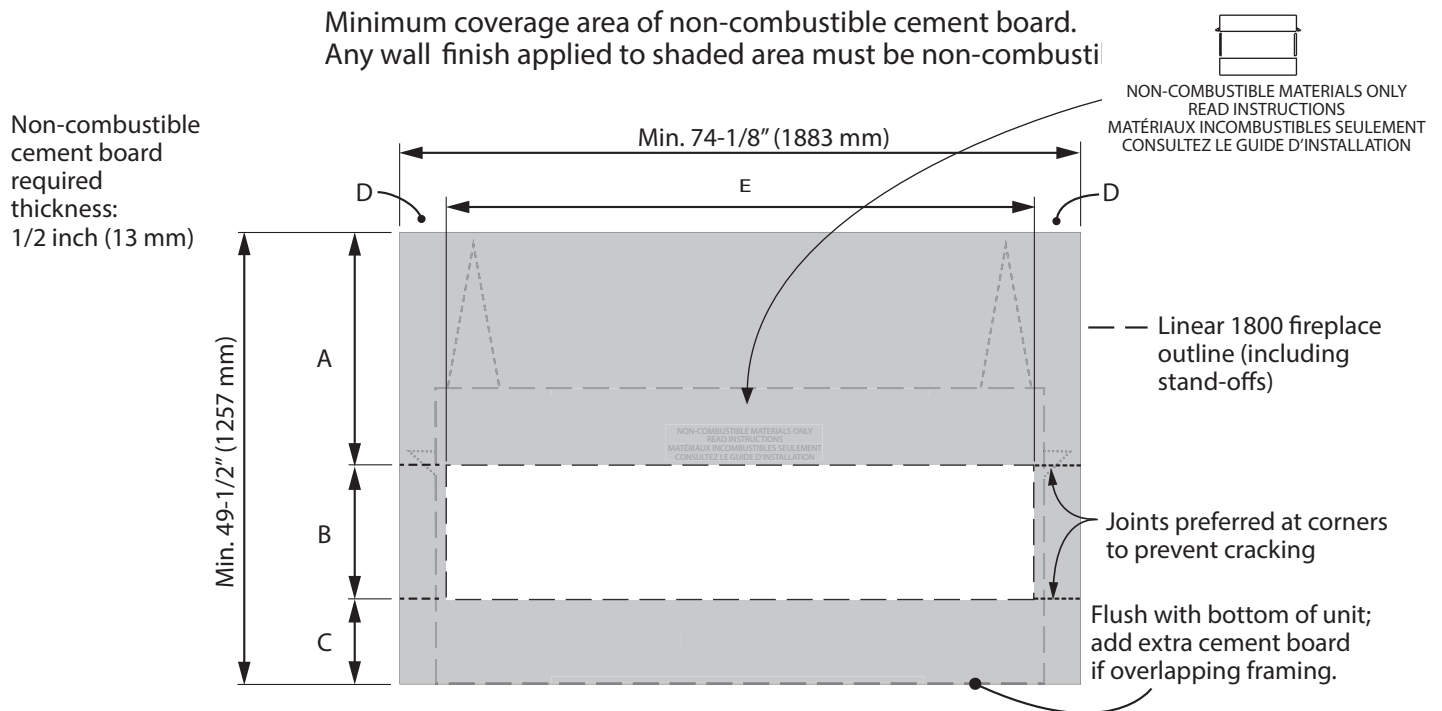

inches [mm]	With 1850 or 1875 trims	with 1830CIK kit
A	Min. 25-1/2 [648]	Min. 25-1/8 [638]
B	14-3/4 [375]	15-13/16 [401]
C	Min. 9-1/4 [235]	Min. 8-9/16 [218]
D	Min. 5-1/16 [129]	Min. 4-1/2 [114]
E	Min. 64 [1626]	Min. 65-1/4 [1657]

Installation Planning

Wall Finish

Non-Combustible Finishing Over Cement Board

Additional non-combustible material such as tile, etc., may be applied over top of the cement board or you may choose to leave it finished clean with no tile, etc.

Be aware that a trim is always required. Finish **should not cover** the trims.

1875 and 1850 Trims

Only the 1875 and 1850 style trims will accept tile, etc. tucked behind them (up to 5/8" thick for the 1875 and up to 1 inch thick for the 1850).

1830 Trim

1830 trim must be installed **BEFORE** cement board. Cement board and finishes are applied to the perimeter of the trim frame. Cement board and finish **CANNOT** be tucked under this trim.

Wider trim (1850) can adjust up to 1" forward of surface of cement board. Cement board tucks behind trim.

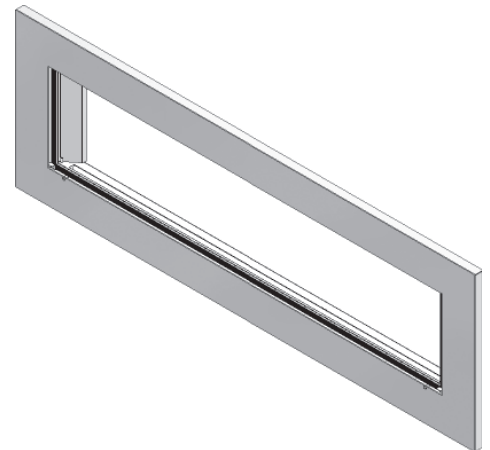

Narrow trim (1875) can adjust up to 5/8" forward of surface of cement board. Cement board tucks behind trim.

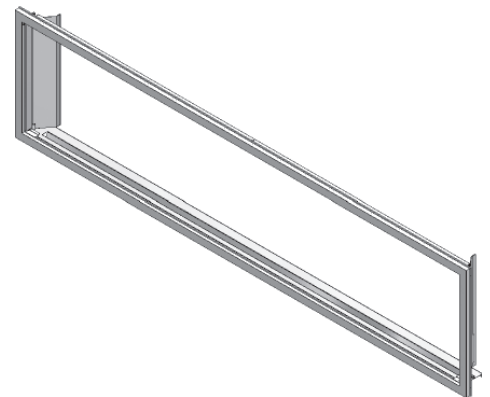

Clean Installation Kit 1830CIK requires HeatShift. Cement board finishes up to perimeter of frame. **Must install BEFORE cement board.**

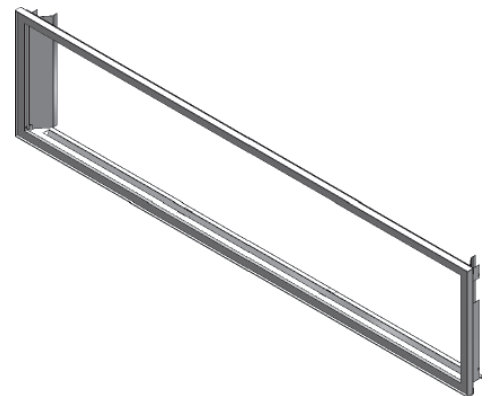

Installation Planning

Wall Finish

Avoiding Cracking Wall Finishes

We recommend installing the optional HeatShift System to reduce the wall temperatures and minimize the possibility of cracking wall finishes.

WARNING

HeatShift System MUST be installed on this appliance when using 1830CIK—Clean Installation Kit.

If a clean finish with no tile, etc. is desired, joints in the cement board and the transition to gypsum board will require special attention if future cracking is to be controlled. Be aware that temperatures on the non-combustible wall surface above the appliance can exceed 200°F (93°C).

Below are some tips on how to best avoid any cracking:

- Allow materials to dry thoroughly before finishing the wall. Cement board has the ability to absorb up to 30 percent of its weight in water and may shrink as much as 1/8" over a 48" length when drying from a saturated condition. Running the fireplace for an extended period before final finishing will help drive out moisture.

- Always pre-drill screw holes through cement board and use screws specific for material used.
- Always use mesh tape over joints.
- Always stagger joints in wall board.
- Behind joints, double up studs or use studs "on the flat" to add extra support to the joint. Adhesive on the backside of wall board behind any joints can help control differential movement.
- Use multiple, thinner coats of joint compound and allow to dry thoroughly between coats.
- Ensure framing materials are dry.
- After finishing the wall, introduce heat gradually to slowly dry any excess moisture rather than drying too fast.
- Avoid notching cement board or tiles around corners of window opening and instead provide a joint that intersects the corner.
- Avoid using large one-piece slab of material with a cut-out in the middle as a surround for the fireplace. Expansion above the opening will cause cracking at inside corners. Provide a joint that intersects the inside corner to avoid cracking.

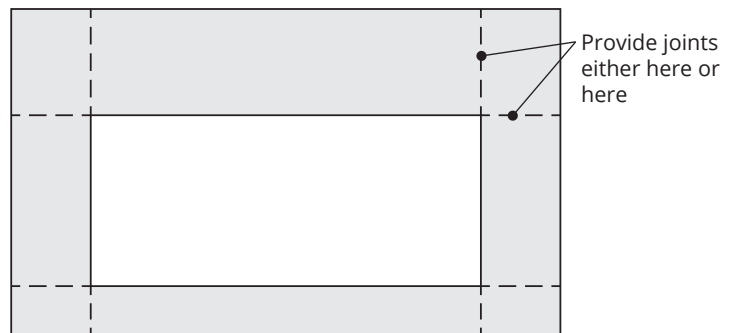
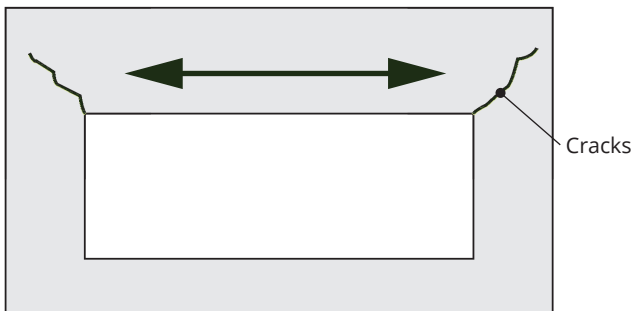

Top Outlet

This unit is supplied with a top vent outlet which should not be field-converted to a rear vent outlet. See "Venting Chart" on page 23 for more information.

Vent Material

This unit is approved for installation using 4 x 6-5/8 inches co-axial direct vent pipe and accessories as listed in the *Approved Venting Components* section on page 8 of this manual. Follow the installation instructions supplied with the individual venting accessories.

Vent Sealing

Seal all **outer** coaxial pipe and elbow joints, including sectioned elbow **outer** joints, using high quality, high temperature 2 inch wide self-adhesive aluminum foil tape (Nashua-322-2 brand or similar). Wrap the tape completely around all **outer** joints and press firmly to seal.

A high temperature black silicone sealant may be used in the **outer** joints as a substitute to foil tape.

Ensure all the pipe joints have a minimum of 1 ¼ inch overlap.

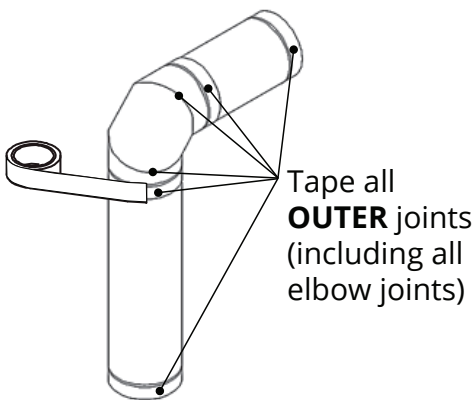

Wall Thickness

The appliance vent is suitable for penetrating a combustible wall assembly up to 8 inches in thickness. A non-combustible wall can be of any thickness up to the maximum horizontal run of vent pipe allowed for the particular installation.

Framing Vent in Combustible Walls & Ceilings

When penetrating through combustible walls and ceilings, frame a minimum of 10 in x 10 in opening and ensure that the insulation is kept clear of the vent pipe using either a wall thimble or an attic insulation shield. Follow the installation instructions supplied with the individual venting components.

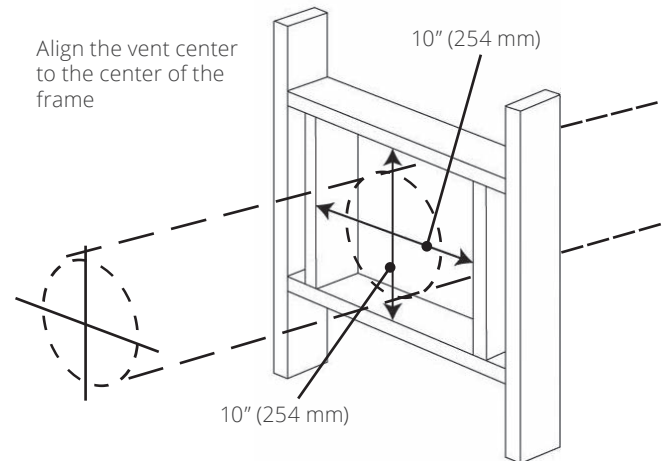

Important Installer Notice - Weather Sealing & Vapor Barriers

It is the installer's responsibility to ensure that vent installations through exterior walls are caulked and weatherproofed in such a manner as to:

- Prevent rain water from entering the wall from the weather side by adequately caulking the outer vent plate to the exterior wall surface.
- Prevent moisture inside the home from penetrating into the wall structure by ensuring the inside wall plate is adequately sealed to the inside vapor barrier.
- Prevent rain water and moisture from entering the walls by sealing the joints between the outer vent tube and the inner and outer wall plates.

We recommend the use of a high quality polyurethane sealant.

All horizontal pipe runs must be graded 1/4 inch per foot upwards in the direction of the exhaust flow. The final pipe length, when terminating through the wall may be graded downwards slightly to prevent water migration.

Venting

Co-Axial

Typical Co-axial Venting Components

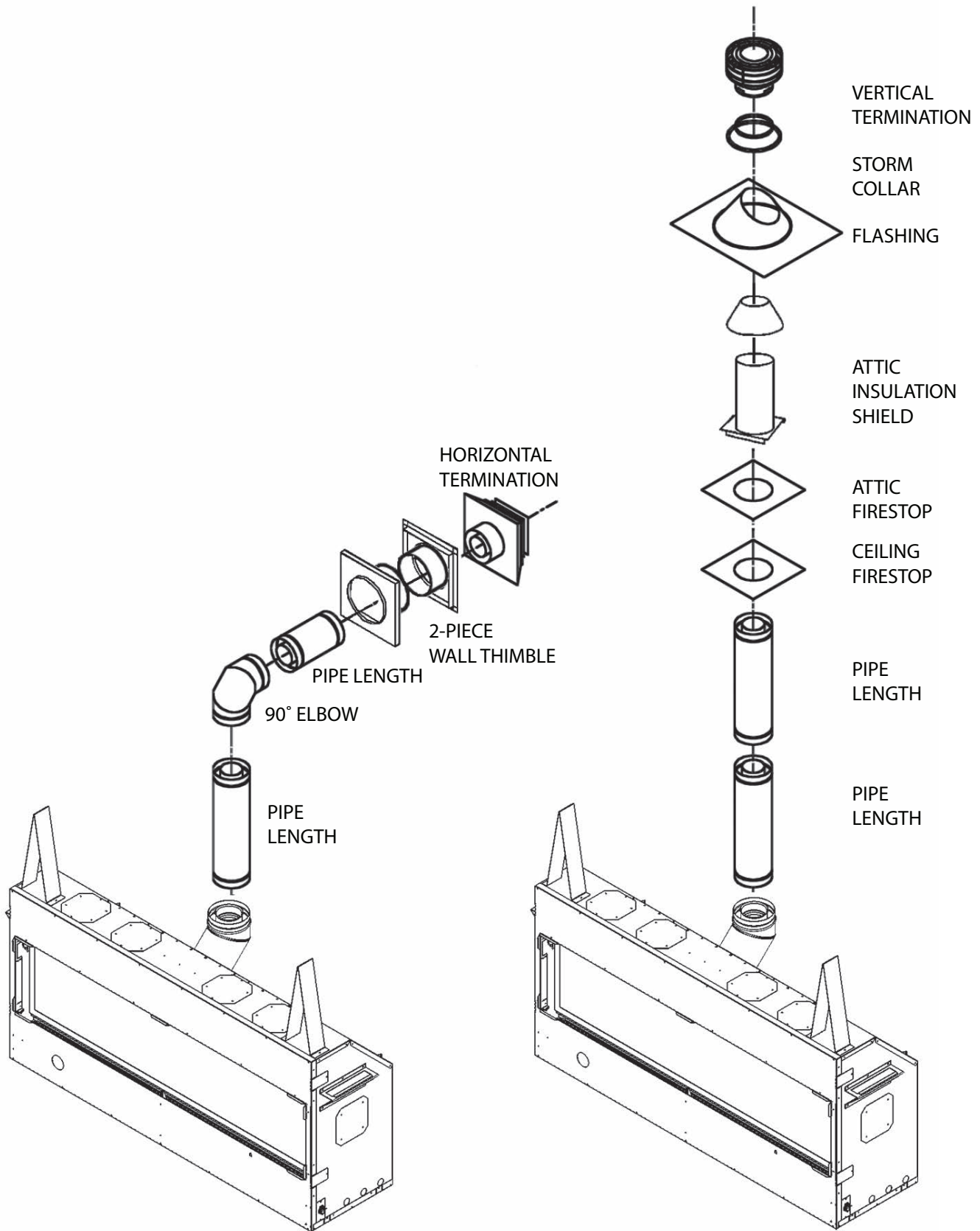

How to Read the Venting Chart

The chart below applies to co-axial roof or wall termination.

1. A minimum vertical rise of 24 inches is required directly off the unit or after first elbow, as shown.
2. The total length of the vent pipe cannot exceed 40 feet.
3. The minimum vertical height with roof termination is 6 feet.
4. Any combination of rise and run can be used as long as they are within the allowable limits shown on the chart below.
5. A maximum of 4 x 90 degrees elbows—or equivalent (2 x 45 degrees = 90 degrees)—can

Venting Chart

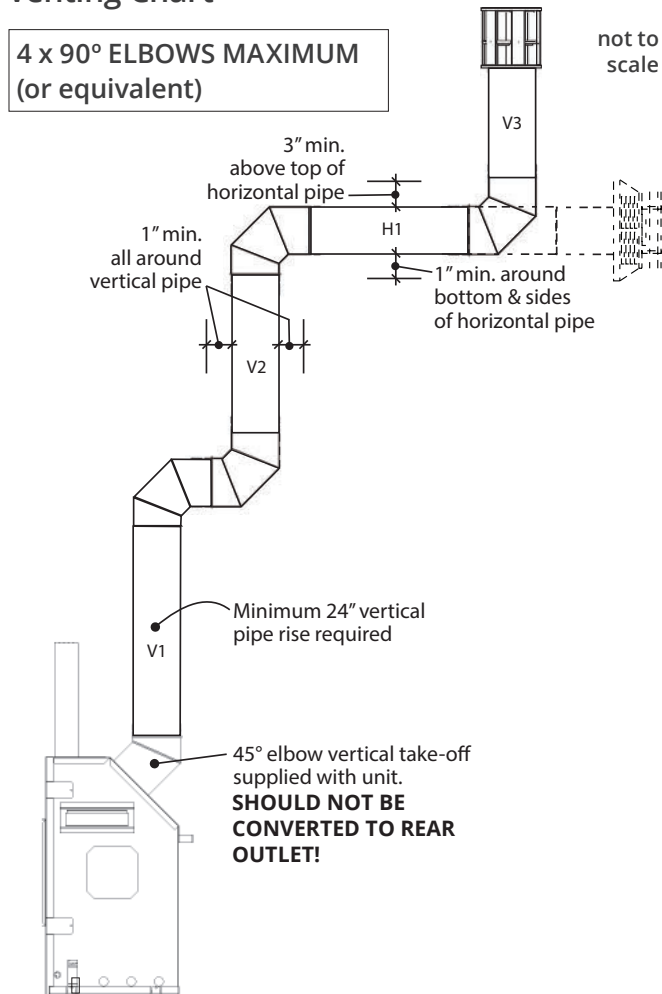

Example 1
 $V \text{ Value} = V1 (4') + V2 (3') + V3 (2') = 9'$
 $H \text{ Value} = H1 (2') = 2'$
 Restrictor position # 1 required

6. Each 90 degrees elbow installed on the horizontal plane is equivalent to a 3 feet horizontal pipe; therefore, 3 feet must be subtracted from allowable horizontal run. (45 degrees elbow is equivalent to 18 inches horizontal pipe.)
7. All horizontal pipe runs must be graded 1/4 inch per foot upwards in the direction of the exhaust flow. The final pipe length, when terminating through the wall may be graded downwards slightly to prevent water migration.
8. A restrictor adjustment is required for most installations having a vertical rise—see “Restrictor Settings” on page 24.

Note: The restrictor is shipped installed at the exhaust exit of the firebox.

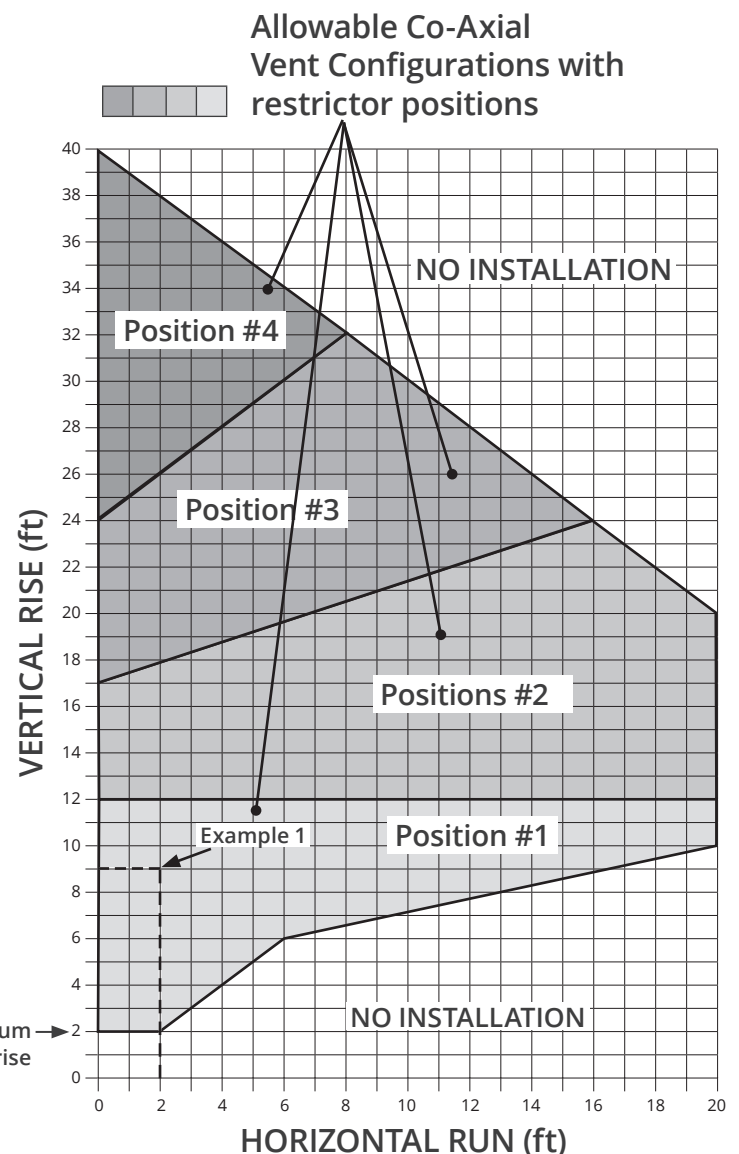

Restrictor Settings

The restrictor is located in the roof of the firebox hidden above the top liner panel. Adjust the restrictor before installation of the top liner panel. Should subsequent adjustment be required, you will need to remove the top liner panel—see “Liners” on page 34.

MOST INSTALLATIONS REQUIRE A RESTRICTOR for improved flame picture and performance. This unit is supplied with a pre-fitted restrictor having four different positions or settings. The restrictor is shipped mounted at the maximum open position which is used for rear venting with no vertical rise. The level of restriction required depends on the vertical rise in the venting system and, to a lesser degree, the horizontal run and number of elbows.

The amount of restriction is based on laboratory tests. The ideal restrictor position may vary slightly, especially when the vent pipe length is near the limits of the acceptable configurations for each type of restrictor.

The chart on the previous page shows the vent restrictor required relative to the length of the vent pipe.

To set the restrictor position:

1. Establish the required position of the restrictor looking up the venting table on the previous page.
2. Release the screws (2) on each side of the restrictor already installed **on the firebox roof port**.
3. Slide the restrictor in the required position.
4. Tighten the screws.

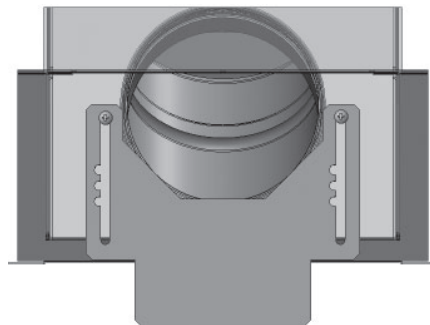
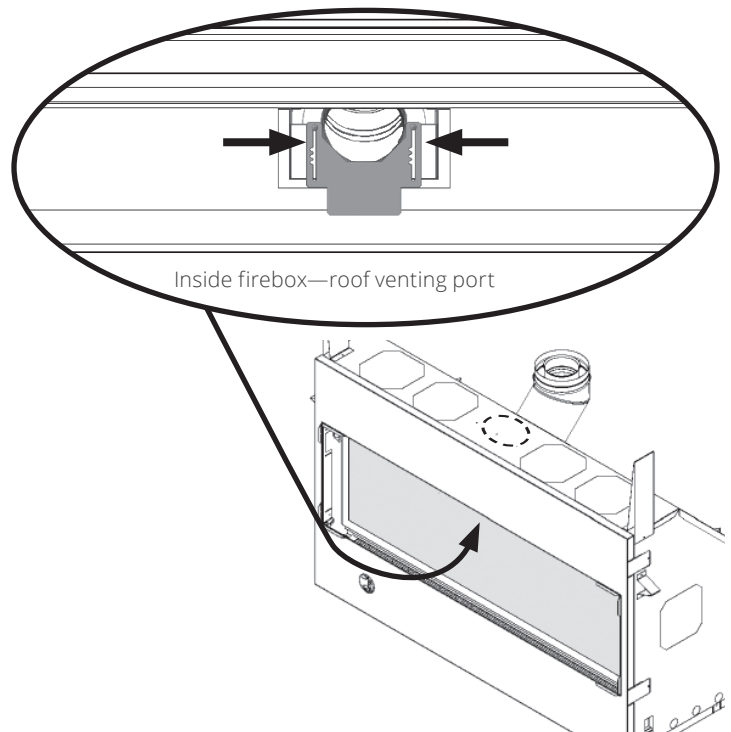

Position #1

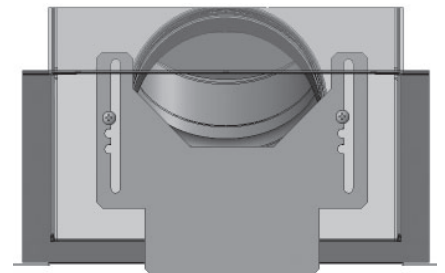

Position #2

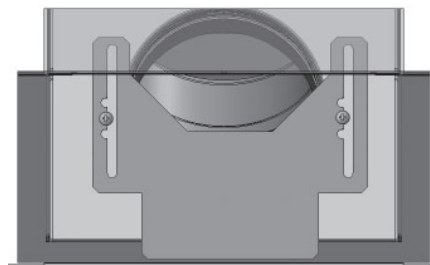

Position #3

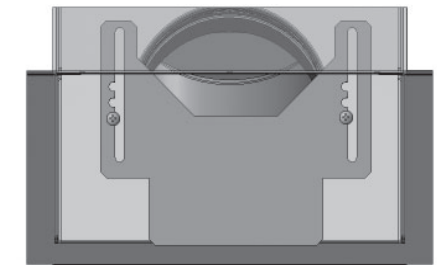

Position #4

Horizontal Vent Termination Location

- The vent terminal must be located on an outside wall or through the roof.
- This direct vent appliance is designed to operate when an undisturbed airflow hits the outside vent terminal from any direction.
- The minimum clearances from this terminal that must be maintained when located on an outside wall are shown in figure below. Any reduction in these clearances could result in a disruption of the

airflow or a safety hazard. Local codes or regulations may require greater clearances.

- The vent terminal must not be recessed into a wall or siding.
- The vent terminal should be positioned where any snowdrifts will not cover it.
- Sidewall vent terminations require a terminal guard such as 658TG or 845TG when accessible—within 7' of ground.

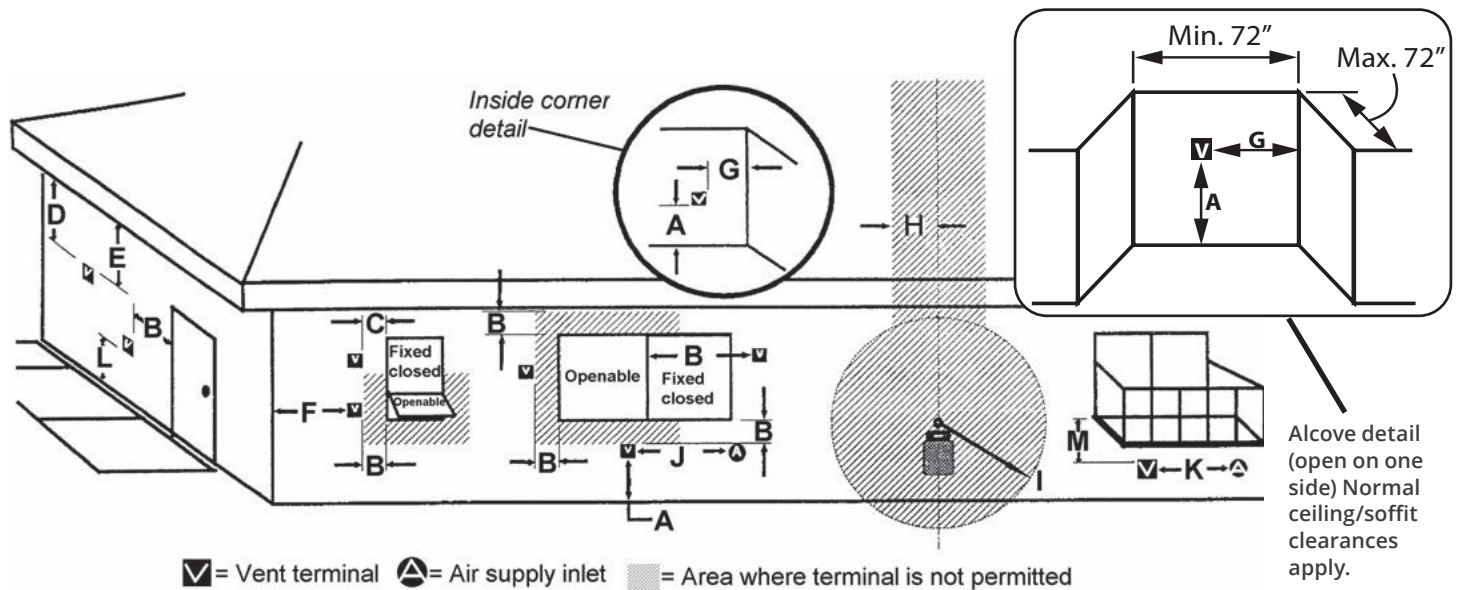

KEY	VENT TERMINAL LOCATIONS - MINIMUM DISTANCES	MINIMUM CLEARANCE	
		Inches	Cm
A	Clearance above grade, verandah, porch, deck or balcony	12	30
B	Clearance to window or door that may be opened	12	30
C	Clearance to permanently closed window (recommended to prevent condensation on window)	12	30
D	Vertical clearance to ventilated soffit located above the terminal within a horizontal distance of 2 feet (60 cm) from the center-line of the terminal	18	46
E	Clearance to unventilated soffit	12	30
F	Clearance to outside corner (measured from the center of vent)	12	30
G	Clearance to inside corner (measured from the center of vent)	12	30
H	Horizontal clearance to center-line of meter/regulator assembly located within 15 feet (4.6 m) below the terminal	36	90
I	Clearance to service regulator vent outlet	36	90
J	Clearance to non-mechanical air supply inlet to the building or the combustion air inlet to any other appliance	12	30
K	Clearance to a mechanical air supply inlet	72	180
L	Clearance above paved sidewalk or a paved driveway located on public property Note: A vent must not terminate directly above a sidewalk or paved driveway, which is located between two single-family dwellings and serves both dwellings. THIS DOES NOT APPLY to direct vent, non-condensing appliances in the Province of Ontario.	84	210
M	Clearance under a verandah, porch, deck or balcony <i>Only permitted if veranda, porch, deck or balcony is fully open on a minimum of 2 sides beneath the floor</i>	12	30

Note: Local codes and regulations may require different clearances.

Vertical Vent Termination

Roof Pitch	Minimum "H" (feet)
Flat to 7/12	1'
Over 7/12 to 8/12	1.5'
Over 8/12 to 9/12	2'
Over 9/12 to 10/12	2.5'
Over 10/12 to 11/12	3.25'
Over 11/12 to 12/12	4'
Over 12/12 to 14/12	5'

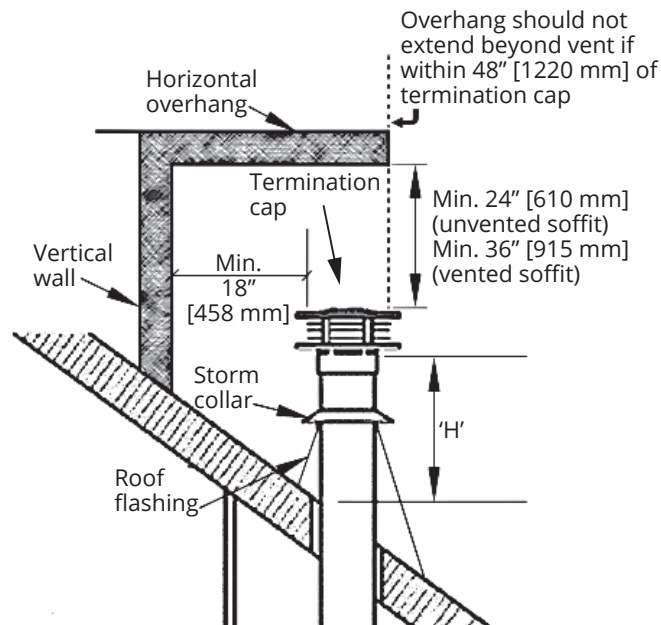

Installation

Unpack Appliance

Beware of sharp edges! Wear gloves!

1. Remove the cardboard wrapping and the wood pallet from the appliance and recycle.
2. Unpack any loose items from around the appliance.
3. Remove the window and set aside in a safe place to avoid damage—see "Remove Window" on page 28.
4. Verify that you have all the components required for the installation, including:
 - approved cement board;
 - liners and fuel bed (in separate cartons);
 - trim kit with barrier screen;
 - venting components and accessories;
 - optional HeatShift system if used;
 - electrical components if installing optional fan or WiFi.

Fit Standoffs

The standoffs are supplied flat on the firebox top and fixed at one end. Swivel up the flat standoffs, bend them as shown and fix the loose end to the top of the firebox.

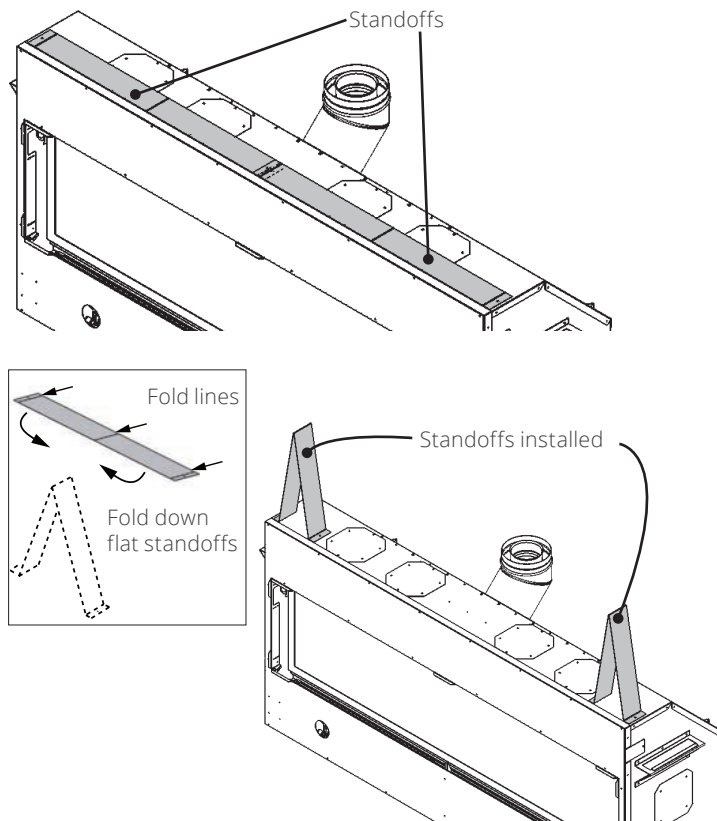

Appliance Preparation

Fit Appliance into Framing

1. Remove the 4 screws retaining the engine to its pallet.

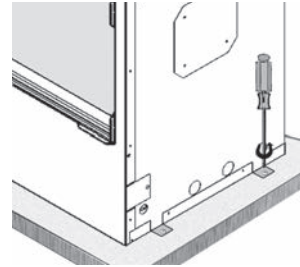

2. Taking great care not to cut your hands on the sheet metal edges, lift the appliance out of its packing base and place it in the framing. *Make sure that the unit is at the right height with consideration to the height of the hearth or combustible flooring.*
3. Fold out four mounting tabs and recess the appliance in the framing as shown.
4. Fasten the unit to framing using 4 screws or nails at the mounting tabs.

Note: The sheet metal front face of the appliance is flush with the framing studs.

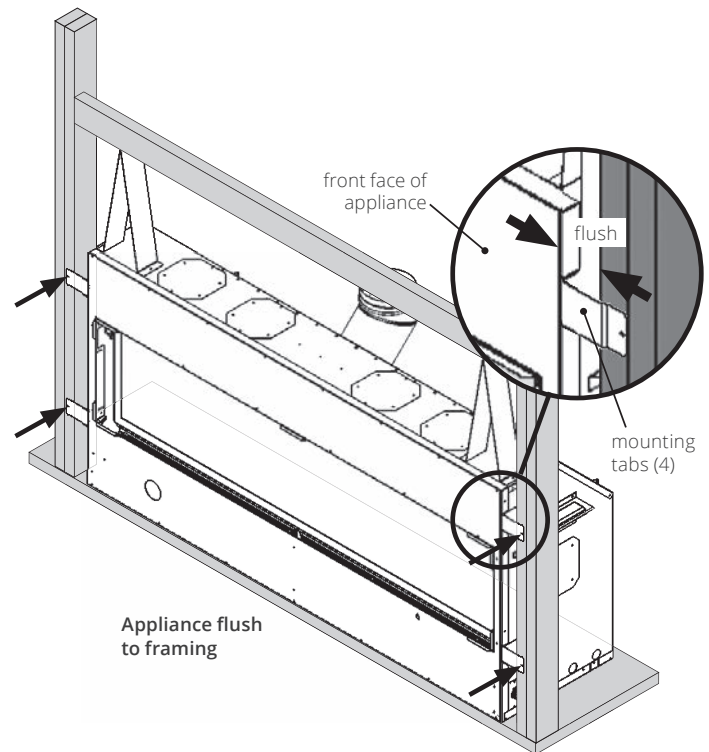

Installation

Appliance Preparation

Remove Window

The window is held in place by a spring-loaded lever on each side.

1. To remove the window, locate the levers on each side of the window towards the top. Using your finger, pull the lever towards you and unhook it from the window frame bracket.
2. Gently pull the top of the window outward.
3. Lift the window out of its bottom railing and set it aside in a safe place to avoid damage.

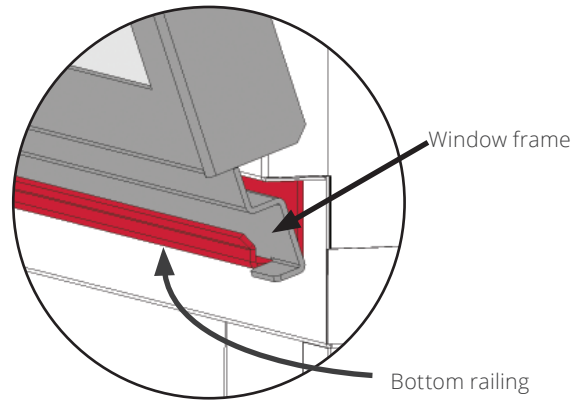

Section Views

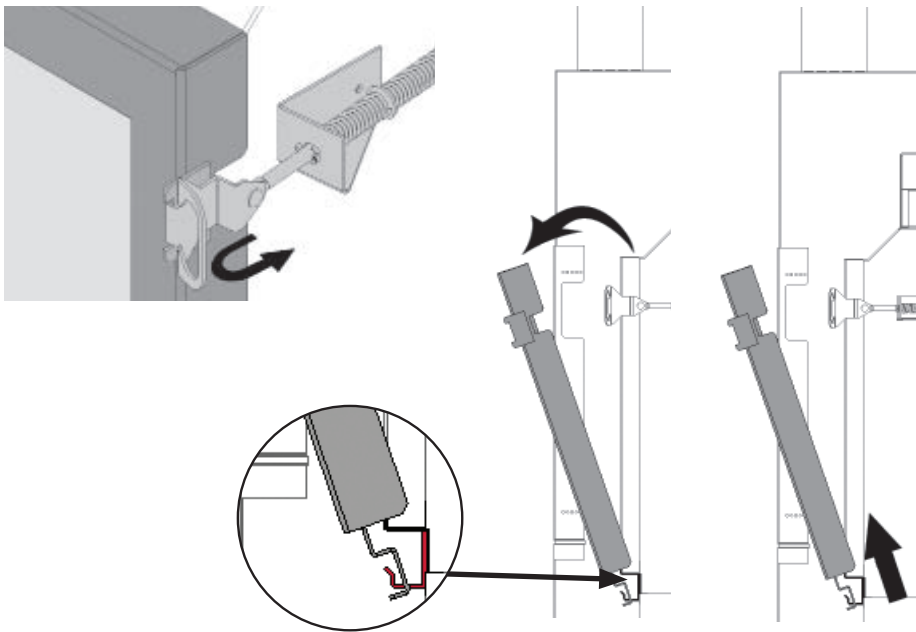

Installation

ONLY If You Are Installing HeatShift!

Perform the following steps and see “Appendix D—HeatShift System” on page 67 for more details regarding HeatShift planning and installation.

Remove Convection Baffle

To be effective, the HeatShift system requires that an internal convection baffle located above the firebox inside the appliance case be removed to allow the hot air flow to convect upwards into ducts installed on the fireplace.

Remove the convection baffle from the appliance. It is held in place by 3 screws located right behind the upper edge of the fireplace opening. Recycle this panel as it is no longer needed.

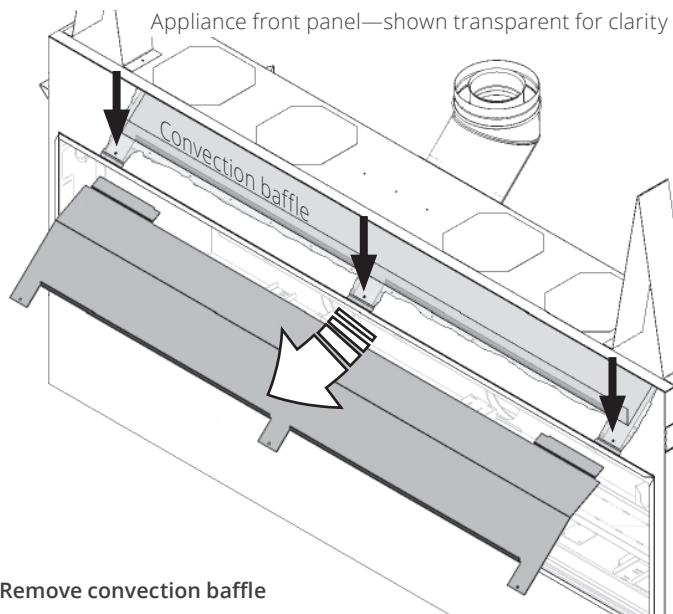

HeatShift™ System—if used

Install HeatShift Take-Off Collars to Appliance

1. Remove the four cover plates on top of the appliance case (6 screws each).

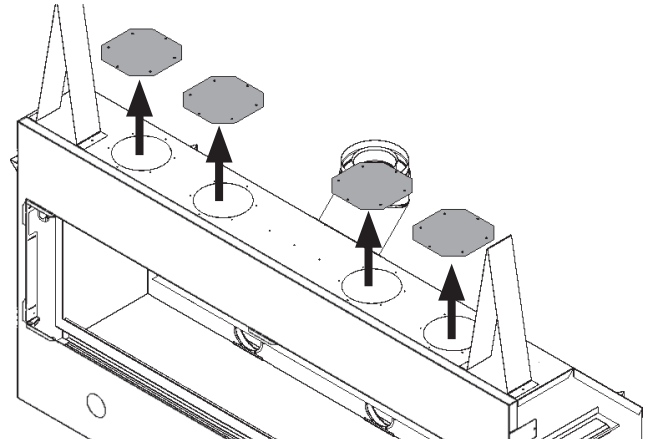

2. Install the take-off collars on the holes on top of the appliance's case (6 screws each).

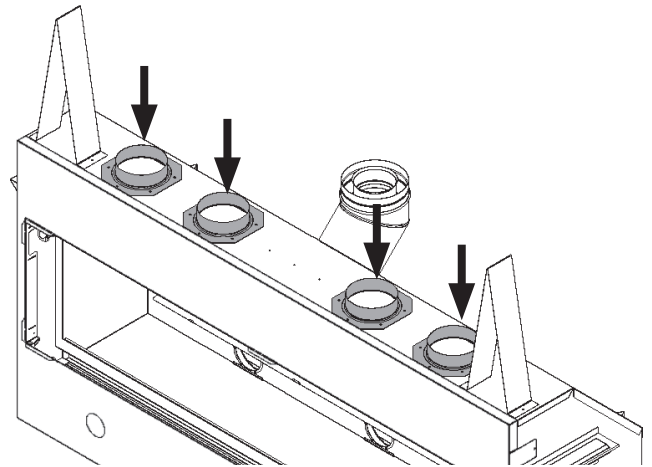

WARNING

The Linear fireplaces requires the removal of the internal convection baffle for the HeatShift system to function properly—read instructions carefully!

WARNING

All FOUR (4) takeoffs MUST BE CONNECTED TO PLENUM(S).

Installation

Electrical Wiring

Install Electrical Wiring (if required)

This section provides information to install the electric pre-wiring required for use with the optional 1595CFKV2 Circulating Fan Kit and/or the GV60WIFI WiFi Kit.

WARNING

All electrical installations must be performed by a qualified electrician and must be electrically wired and grounded in accordance with local codes or, in the absence of local codes, with the National Electrical Code, ANSI/NFPA 70 or the Canadian Electrical Code, CSA C22.1.

WARNING

NO ELECTRICAL CONNECTION ALLOWED for any outdoor installation!

Electrical Requirements

1595CFK—120 VAC, 60 Hz, less than 1 amp

GV60WIFI—6 VDC (from receiver), less than 1 amp

General Requirements

Both optional 1595CFK and GV60WIFI kits require a GV60VM power supply (known as a V-Module), which includes a three-prong grounded plug to plug into a grounded receptacle installed within the fireplace enclosure by a qualified electrician.

The receptacle, housing, and strain relief are supplied and installed as part of the fireplace.

Notes

- We recommend connecting the electrical box even if the optional accessories have not been purchased. It is much easier to wire before wall finish is applied.
- Wiring within the receptacle enclosure must have a minimum 90°C temperature rating.
- Wire nuts not included.

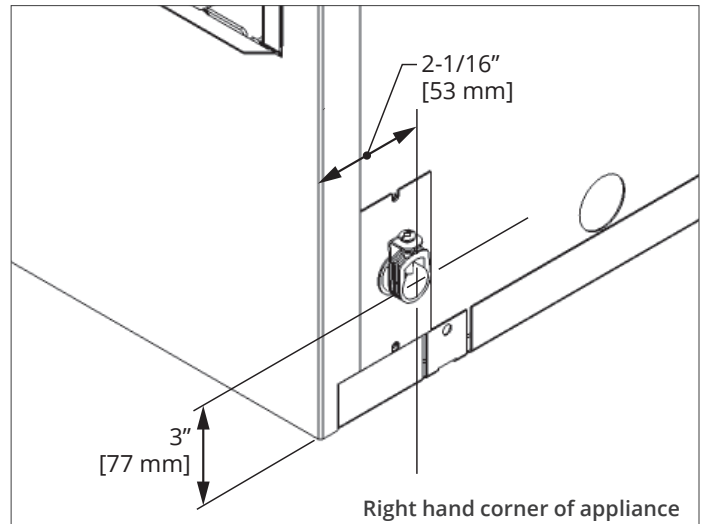

Installation

1. Locate the electrical housing. It is behind the front panel of the fireplace in the bottom right corner.

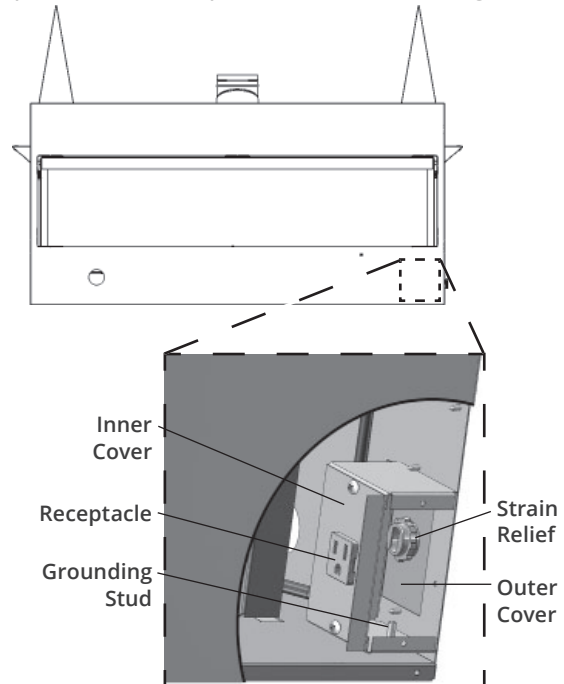

2. Remove the inner cover (2 screws).

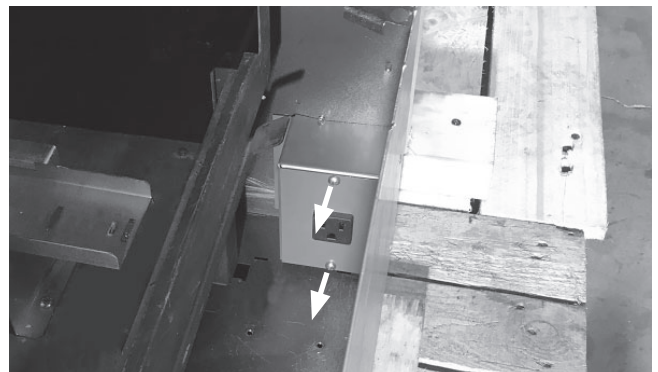

Installation

3. Pull the inner cover and receptacle (attached) out of the fireplace.

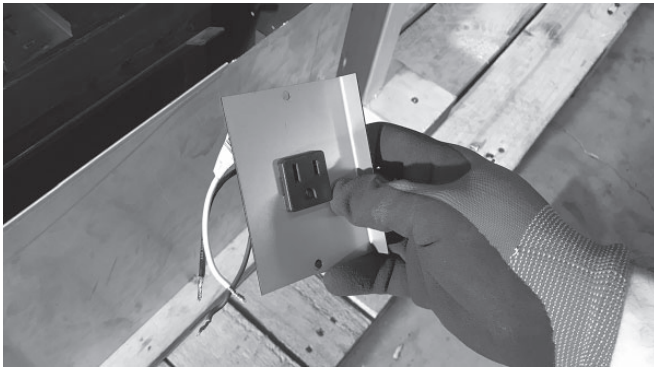

4. Thread the cable through the stud and the strain relief in the fireplace case. **Do not tighten the clamp yet.** Pull as much wire through the case as you need to wire the receptacle outside the case.



5. Strip wire and terminate grounded receptacle using wire nuts (not included). Place the connected receptacle back in the fireplace, and pull excess cable back through the strain relief.

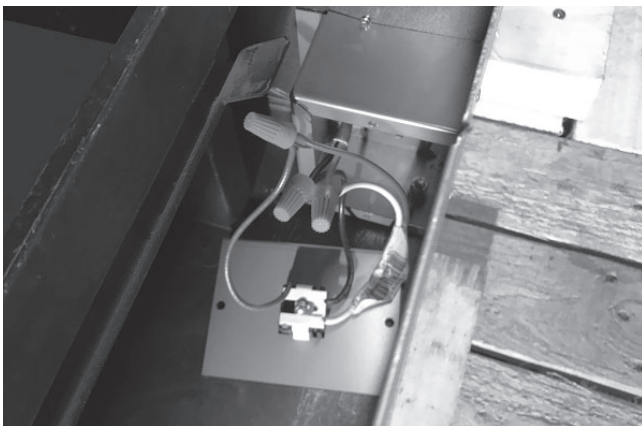

Electrical Wiring

6. Place the inner cover and receptacle in position and replace 2 screws.

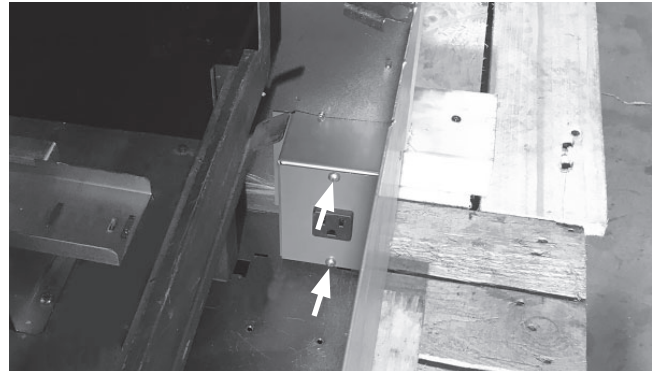

7. Leave your desired cable slack in the electrical box, and tighten the strain relief cable clamp outside of fireplace casing and secure and excess wire to framing.

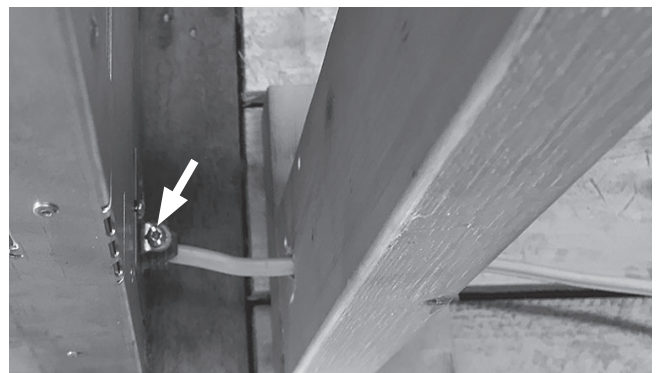

Set-up Gas Supply

The gas supply inlet connection is a 3/8" NPT male connector located on the left hand side of the firebox.

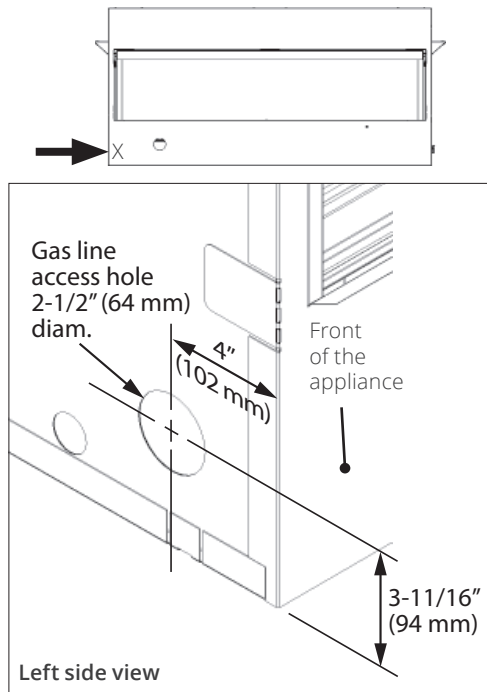

The unit is supplied with a stainless steel flex line to allow the appliance to be disconnected for service. An individual shut-off valve (not supplied) is required on the supply line ahead of the flex connector.

Use only new black iron, steel pipes, CSST, copper tubing, or corrugated stainless steel tubing if acceptable—check local codes. Note that in USA, copper tubing must be internally tinned for protection against sulfur compounds.

Unions in gas lines should be of ground joint type.

The gas supply line must be sized and installed to provide a supply of gas sufficient to meet the maximum demand of the appliance without undue loss of pressure.

Sealant used must be resistant to the action of all gas constituents including propane gas. Sealant should be applied lightly to male threads to ensure excess sealant does not enter gas lines.

Installation

Gas Supply

Pressure test the supply line for leaks.

The appliance and its individual shut-off valve must be disconnected from the gas supply piping system during any pressure testing of that system at test pressures in excess of 1/2 psig (3.5 kPa).

The appliance must be isolated from the gas supply piping system by closing its individual manual shut-off valve during any pressure testing of the gas supply piping system at test pressures equal to or less than 1/2 psig (3.5 kPa).

Failure to either disconnect or isolate the appliance during pressure testing may result in regulator or valve damages and void the warranty. Consult your dealer in case of damages.

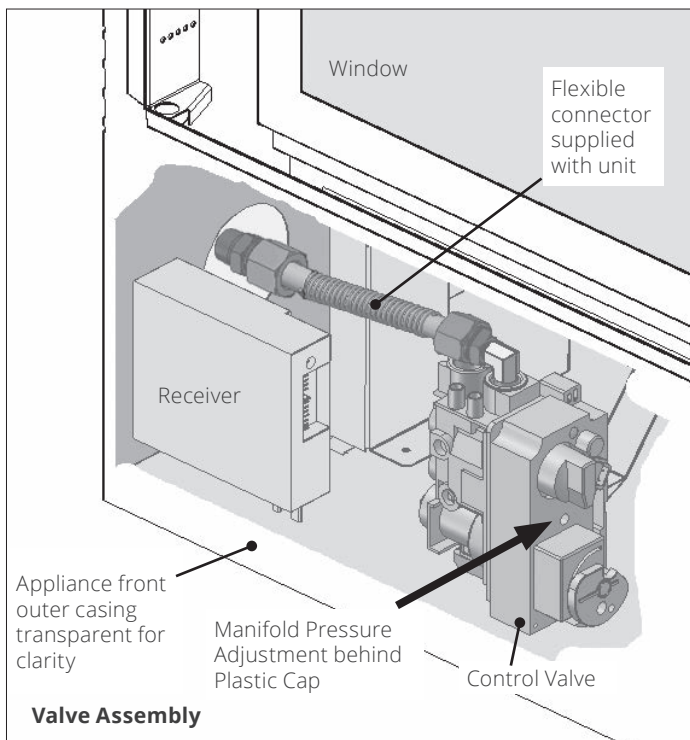

Pressure Test Points

The minimum supply pressure is given in the section "Specifications" on page 6.

All piping and connections must be tested for leaks after installation or servicing. All leaks must be corrected immediately.

When testing for leaks:

- Make sure that the appliance is turned off.
- Open the manual shut-off valve.
- Test for leaks by applying a liquid detergent or soap solution to all joints. Bubbles forming indicate a gas leak.

Caution

Never use an open flame to check for leaks!
Correct any leak detected immediately.

The pressure test tapping locations are shown in the figure at right. An internal regulator within the valve controls the burner manifold pressure. The correct pressure range is shown in the table in section "Specifications" on page 6. The pressure check should be made with the burner alight and at its highest setting. See "Appendix A—Lighting Instructions" on page 58 for full operating details.

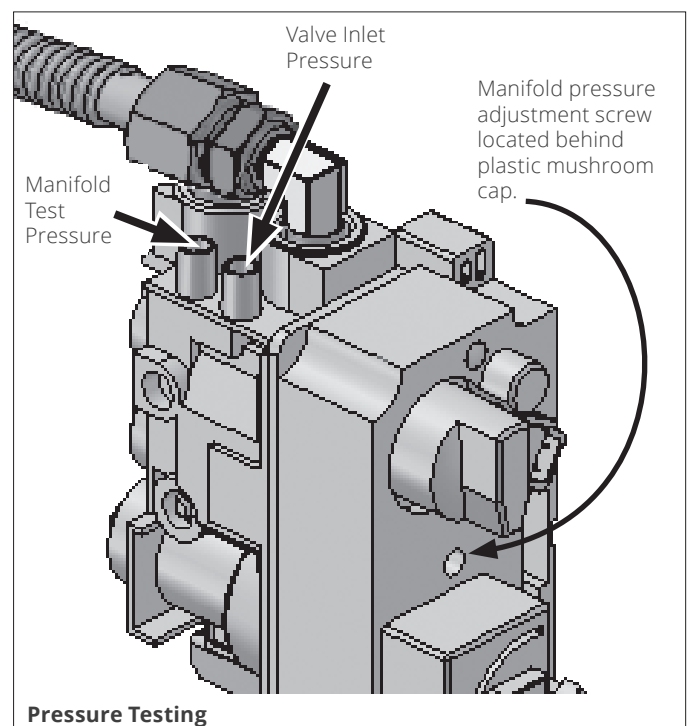

Installation

Liners

Liner Installation

The liners install in the manner outlined below **except the 1825RGL Reflective Glass Liners**, see instructions supplied with those liners.

Unpack the liner panels carefully.

1. Inside the firebox, on the top of each side, release the screw of the side panel anchors (one per side) just enough to allow them to rotate.



2. Place the right end panel against the right wall of the firebox and secure it with the anchor.

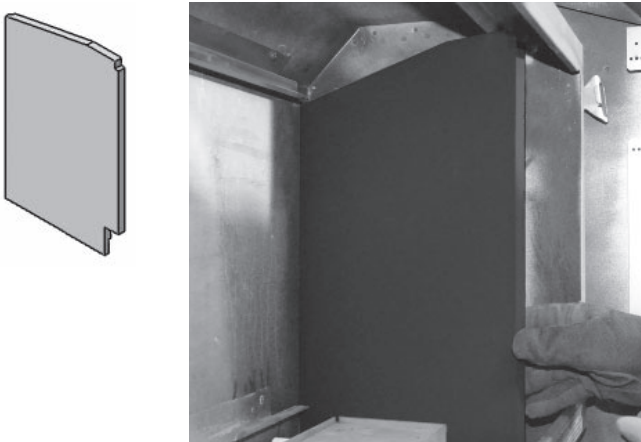

3. Install the left end panel in the same manner.
4. The rear panel is supplied in three sections which overlap each other. The two outer sections are identical and overlap the center section.

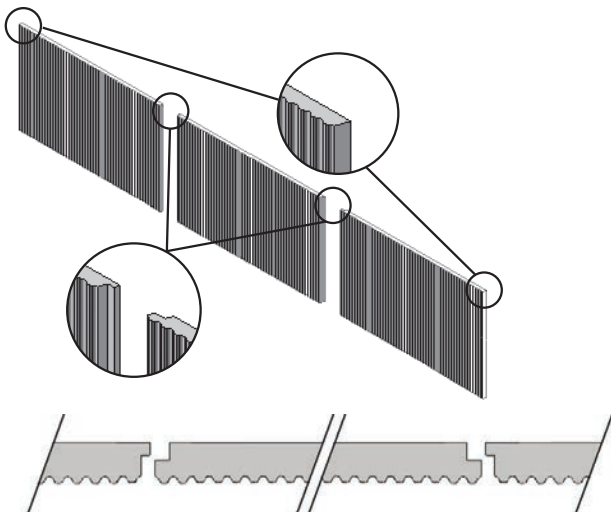

Rear panel sections—top view

- a) Identify the right side outer section. From the middle of the firebox, insert the section upwards behind the top railing and place it on the ledge above the ports. Slide the section sideways to the right into position, behind the tabs, as far as possible.

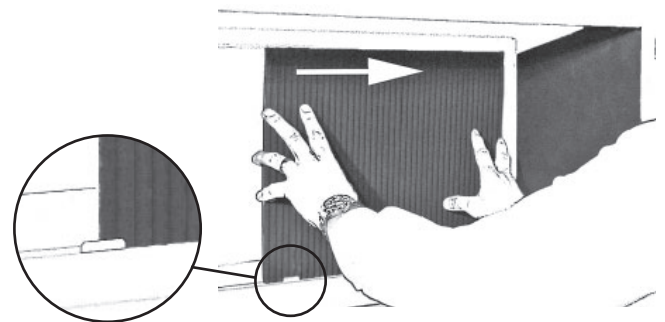
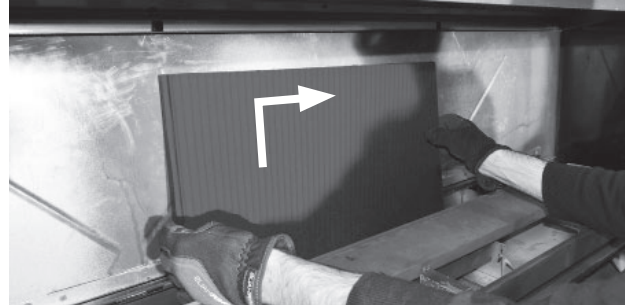

- b) Identify the left side outer section. Like the right one, insert it from the middle of the firebox and slide it to the left, behind the tabs, as far as possible.
- c) Insert the center section upwards behind the top railing and place it on the ledge.
- d) Pull back both side sections towards the middle to overlap the center one.

Installation

Liners

5. The top panel is supplied in two identical sections. The sections are beveled and the smooth black 'fire side' is notched at the front and straight at the back. When installed, the top panel rests on the front and back railings.
 - a) Insert one section of the top panel, smooth black surface down. Push the section on the left side as far as it will go—there is a stop tab at the left end of the railings.



- b) Insert the second section in the same manner. Push it against the first section and ensure there is no gap between the sections.



NOTE: If gapping occurs between each section of the rear panel, a lift tab located on each end of ledge can be bent by hand to close the gap.

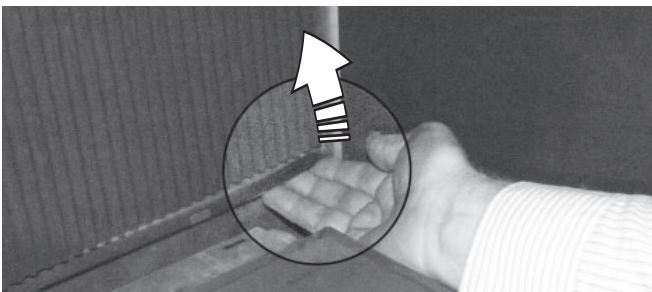

Installation

Fuel Beds

Driftwood Log Kit 1800DWKV2

Materials Required

1800DWKV2 Driftwood Log Kit, which contains:

- 8 Driftwood logs
- 10 pebbles of assorted colors
- 1 bag of beige vermiculite
- Left and right hand platforms

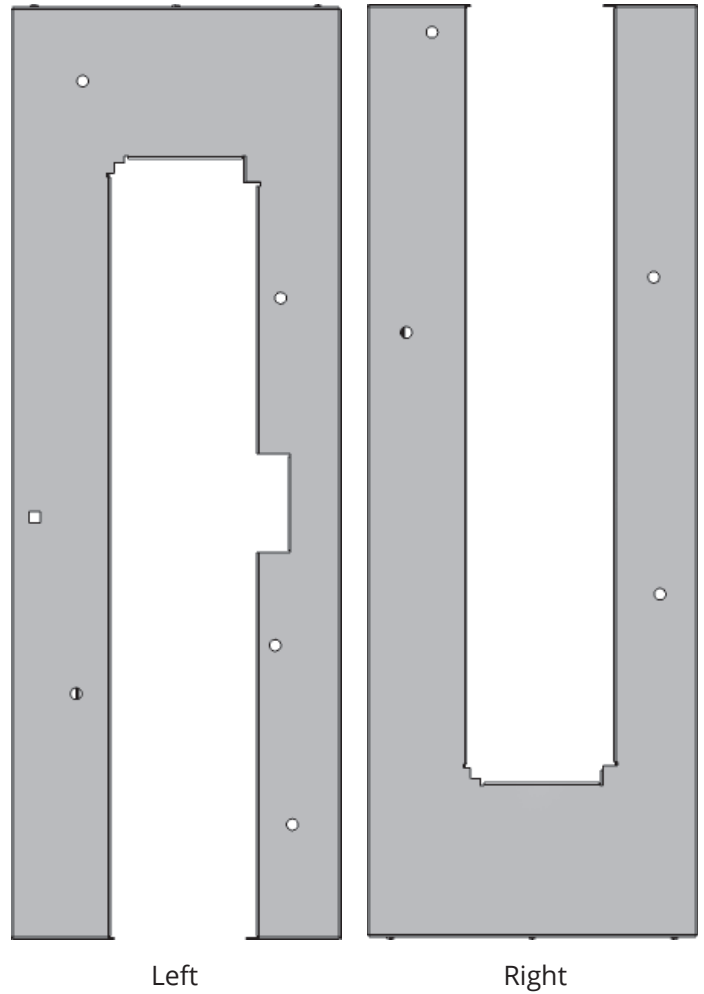
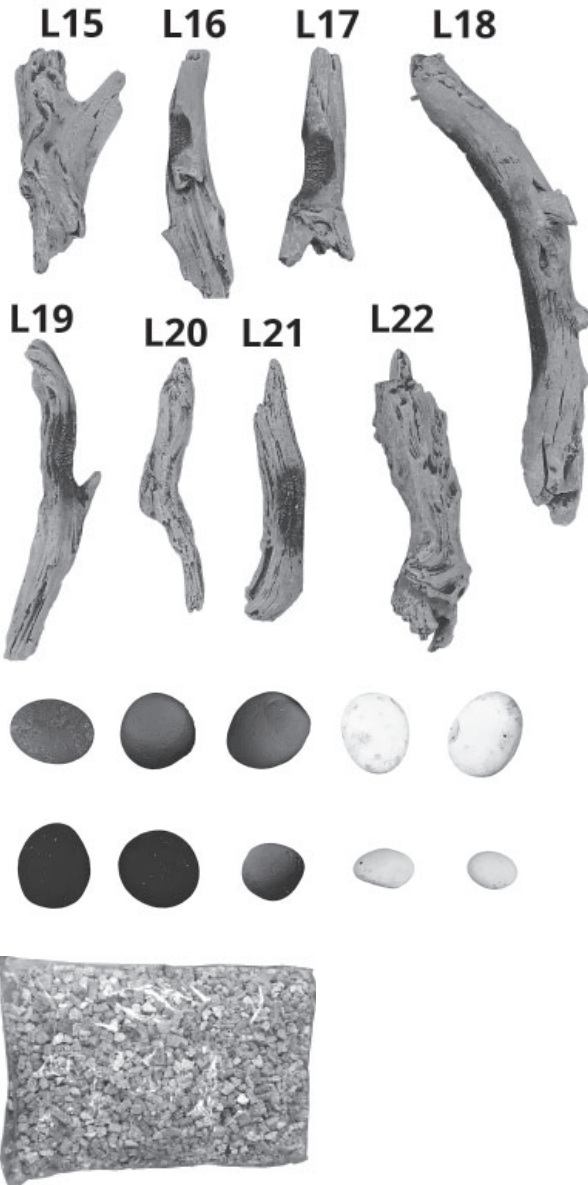

Installation

Fuel Beds

Installation

The following instructions show the best positions for the logs and other pieces to obtain the best fire.

1. Place left and right sides platform around the burner as shown (note pilot light cutout). The platform rests in place and is not screwed down. The openings go underside.

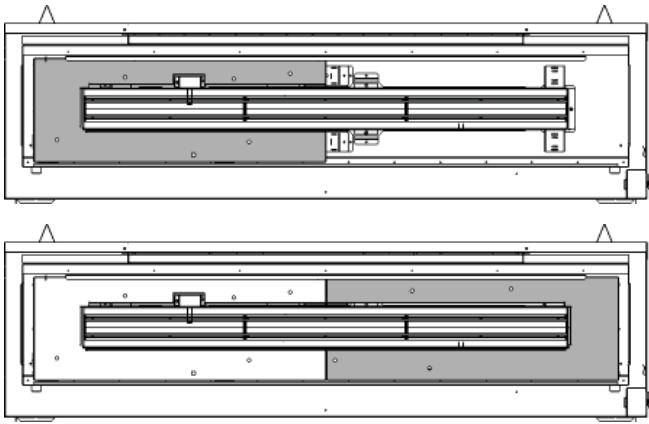

2. Place log L15 on the rear corner of the burner. A cutout under the log helps place it..



3. Place log L16 on top of L15, across the burner, to the front of the media platform as shown.



4. Place log L17 on top of the pilot shield, across the burner, to the front of the media platform as shown.



5. Place the pin on log L18 into the hole on the rear media platform. Place L18 over the burner to the front of the media platform as shown.

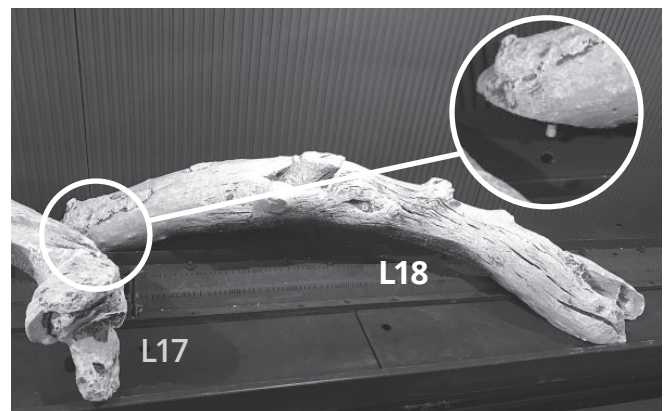

6. Place log L19 on top of L18 as shown. Rest the other end on the front of the media platform.

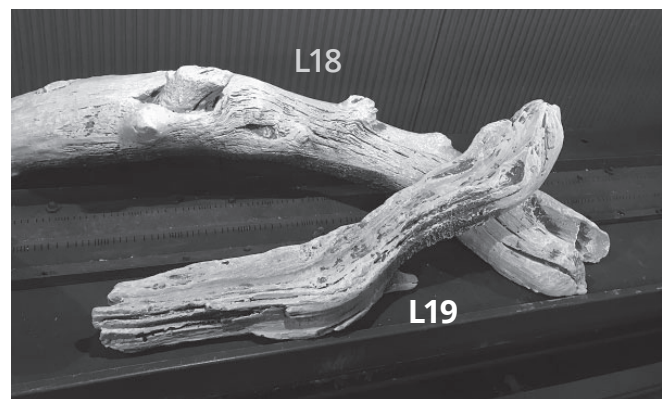

Installation

Fuel Beds

- Place log L22 on the rear corner of the burner. A cutout under the log helps place it..



- Place log L21 on top of L22, resting on the front of the media platform.

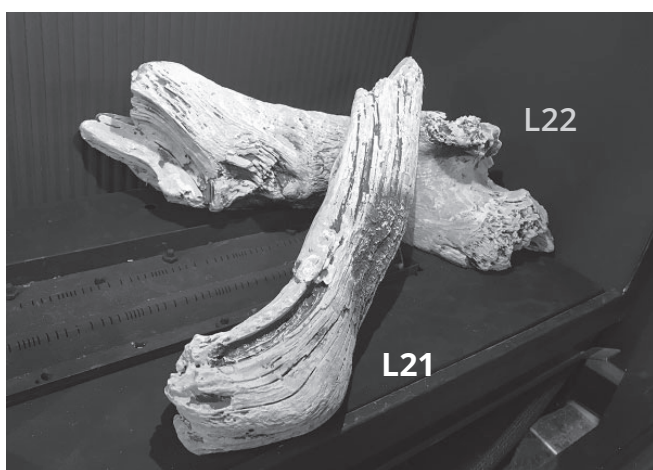

- Place log L20 on the rear of the media tray, between L18 and L22.

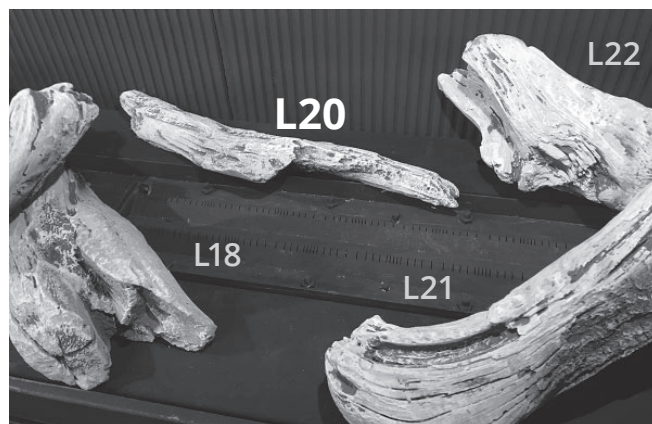

- Place vermiculite by hand (do not pour vermiculite as the bag contains dust particles that could block the burner ports) and cover the burner, and onto the surrounding media tray as well.
- Place pebbles on the vermiculite to your preference.

IMPORTANT

Approved for use only with vermiculite provided with your Valor fireplace. The use of any other products may void your fireplace warranty.

WARNING

Choking Hazard! Ensure that the fireplace area is clear of vermiculite particles as these could be ingested by small children. Vacuum area after installation.

Finished Assembly

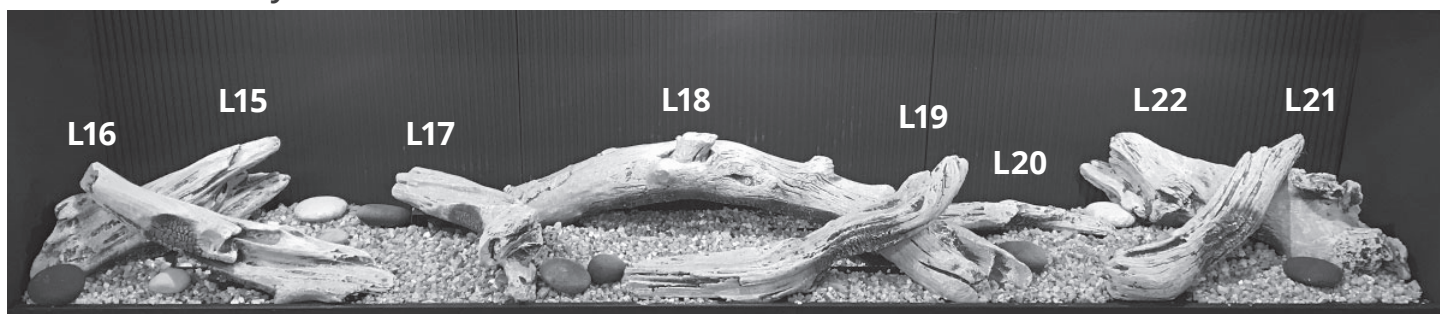

Installation

Fuel Beds

Decorative Glass Murano Kit 1800DGMV2

Materials Required

1800DGMV2 Decorative Glass Murano Kit, which contains:

- 6-piece glass platform
- 4 sheet metal runners
- 2 sheet metal cross runners
- 2 bags of clear fireglass

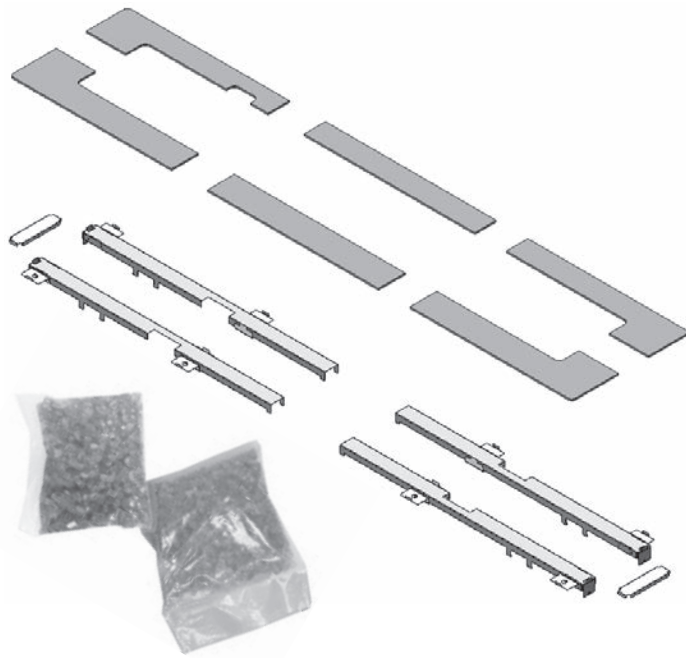

Installation

Carefully unpack the kit.

1. Install the 4 sheet metal runners around the burner. The open end of the runners are oriented toward the middle and the tabs at the bottom. The tabs fit into the slots of the burner supports. The tabs with holes are nearest to the front of the fireplace.

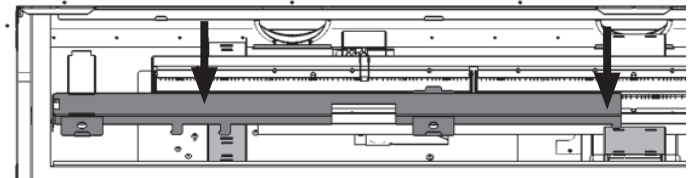

2. Install the sheet metal cross runners at each end of the assembly, linking the front and rear runners by inserting the cross runners tabs into the slots of the runners.

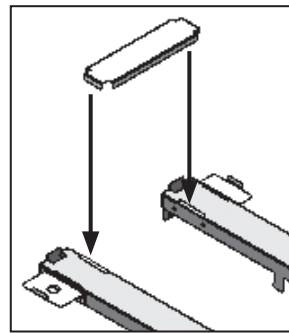

3. Place the glass pieces as shown, smooth side up, on the runners. All around the runners, vertical tabs keep the glass pieces together. Note that the rear glass pieces are narrower than the front pieces.

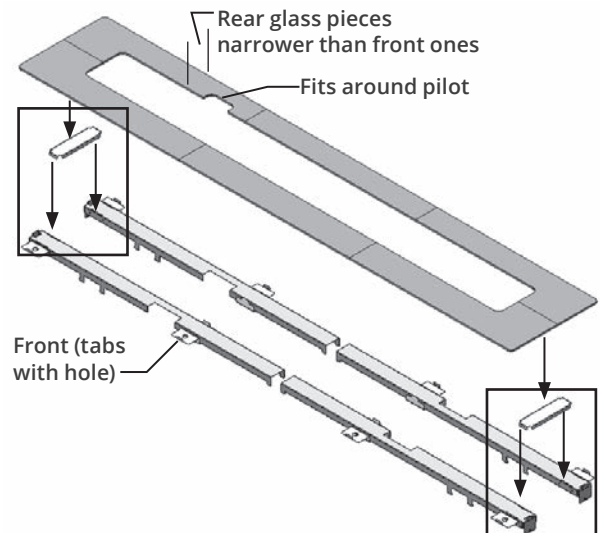

Installation

Fuel Beds

- Carefully place, by hand, the fireglass on the surface of the burner patting it gently to form a single layer to the approximate level of the top edge of the flange around the burner. **Do not pour from the bag or put too much to avoid blocking the burner ports.**



- Some fireglass may be added on the platform to cover the edge of the burner.
Note: Ensure the area **within** the pilot shield is clear of fireglass.

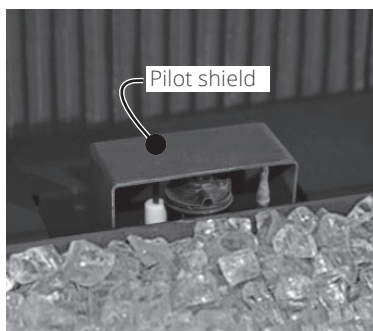

IMPORTANT

Approved for use only with the fireglass provided with your Valor fireplace or the tempered crushed fireglass brands *American Fireglass™* or *firegear*. The use of any other products may void your fireplace warranty.

WARNING

Choking Hazard! Ensure that the fireplace area is clear of fireglass particles as these could be ingested by small children. Vacuum area after installation.

Installation

Fuel Beds

Splitwood Kit 1800SWK

Materials Required

1800SWK Splitwood Log Kit, which contains:

- 12 Splitwood logs
- 4 bags of coal embers
- 1 bag of grey splinters
- Left and right hand platforms

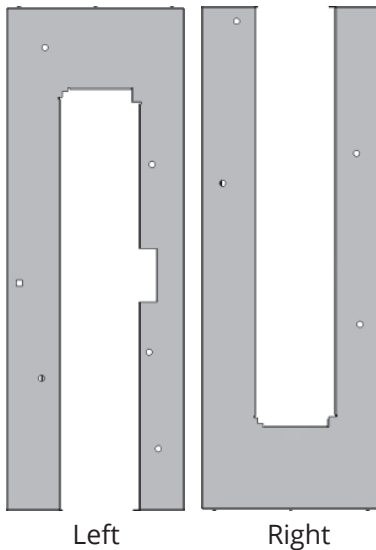
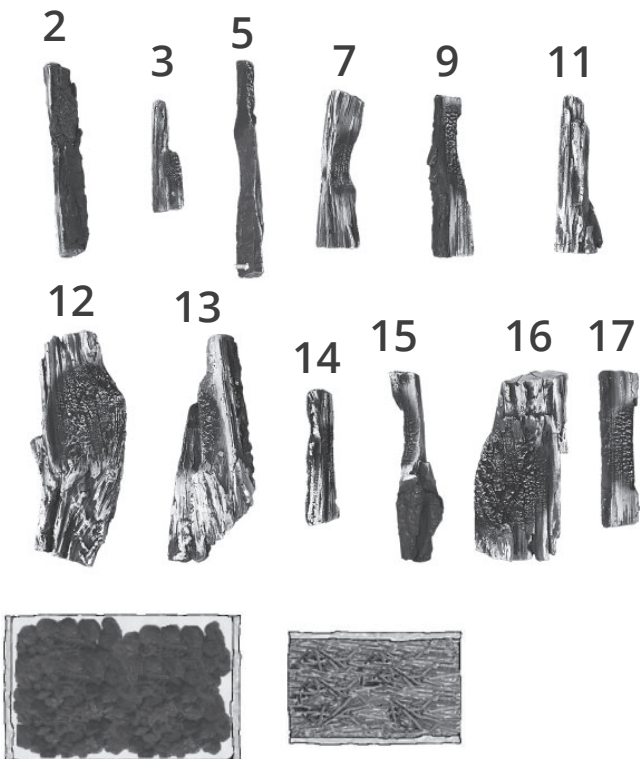

Installation—Platform

1. Place left and right sides platform around the burner as shown (note pilot light cutout). The platform rests in place and is not screwed down. The openings go underside.

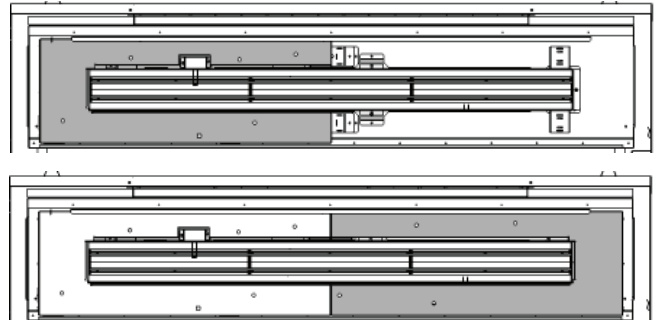

Installation—Logs

The following instructions show the best positions for the logs and other pieces to obtain the best fire.

1. Place log 12 with the right angle cutout under the log around the rear left corner of the burner.

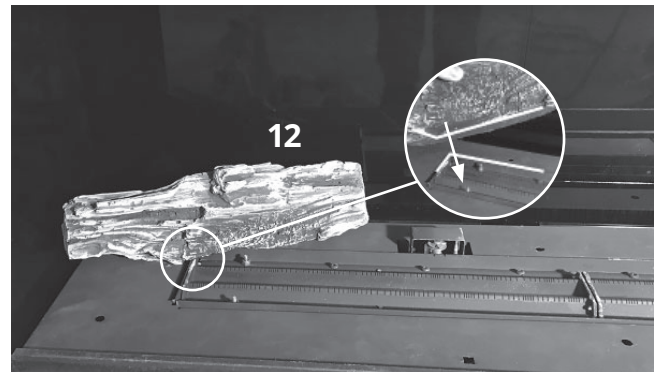

2. Place log 2 on top of 12, and across the burner to rest on the platform as shown.



Installation

Fuel Beds

- Place log 3 at the front left corner of the burner.

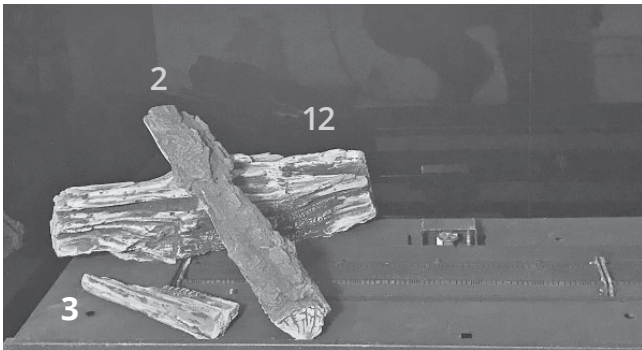

- Place log 13 with the pin inserted in the platform as shown.

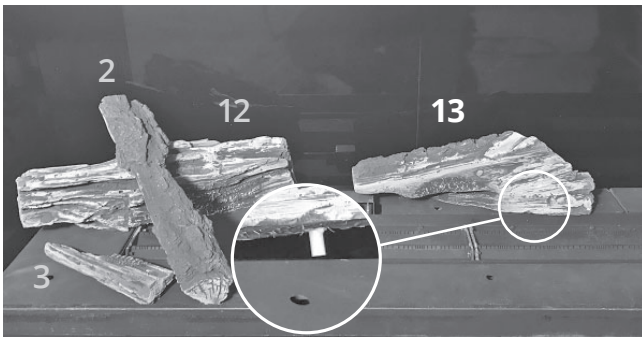

- Place log 5 on top of 13, across the burner with the pin inserted as shown.

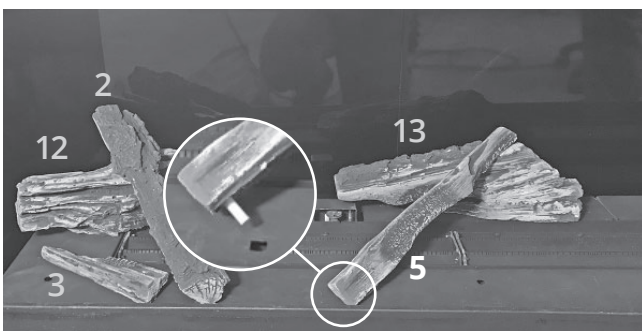

- Place log 14 on top of 5, onto the front platform.



- Place log 17 across the burner with the pin in the hole in the front platform.

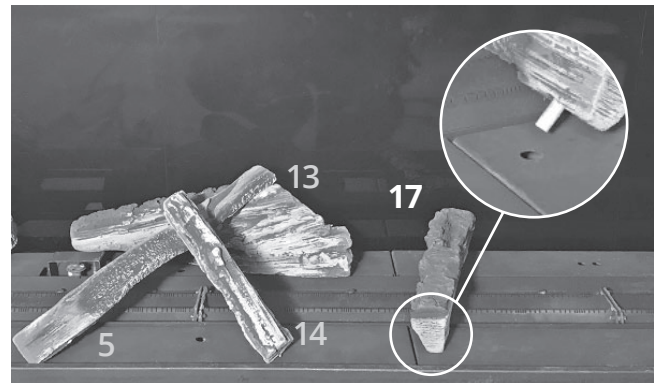

- Place log 7 on top of 17 and onto the front platform.

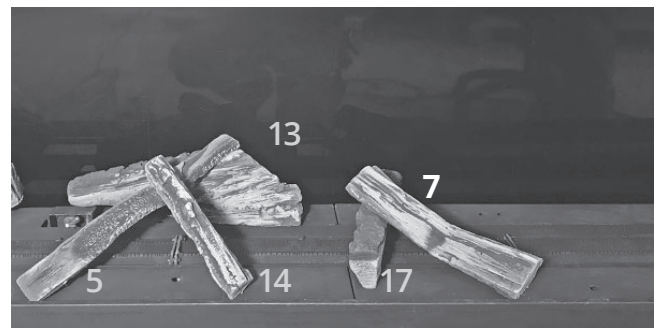

- Place log 9 across the burner with the pin in the hole as shown.

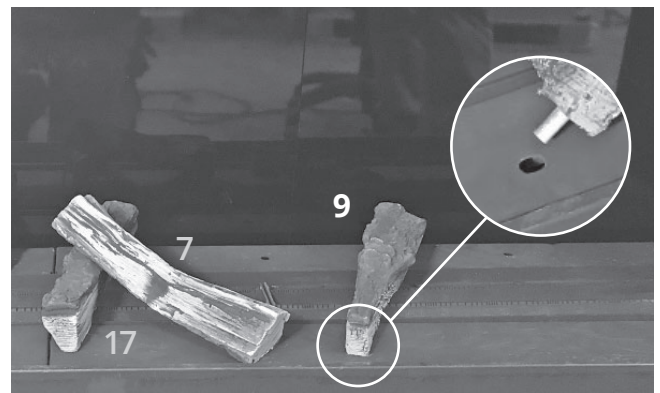

- Place log 15 on top of 9 onto the rear platform.

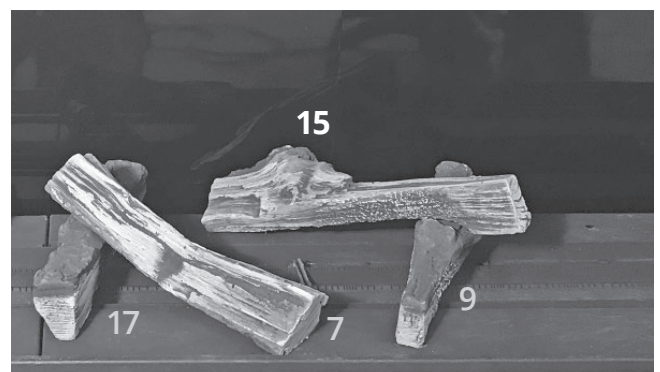

Installation

Fuel Beds

- Place log 16 with the right angle cutout under the log around the rear right corner of the burner.

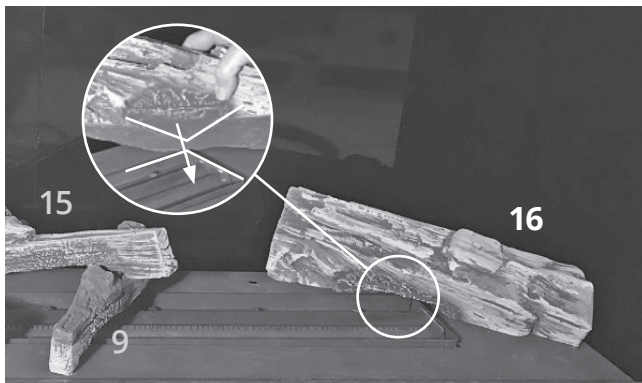

- Place log 11 on top of 16 to the front platform as shown.

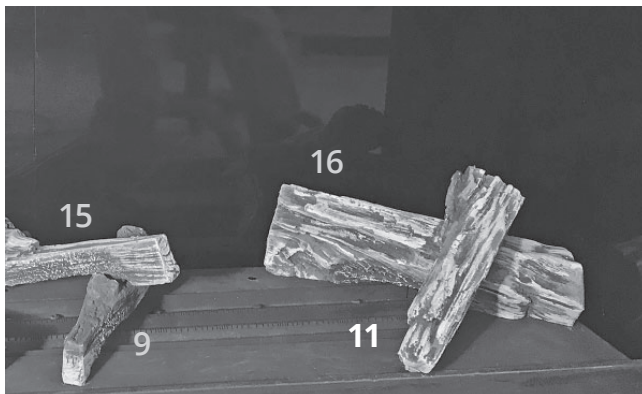

- Place embers by hand onto the burner. Do not pour embers as fine dust can block burner ports.

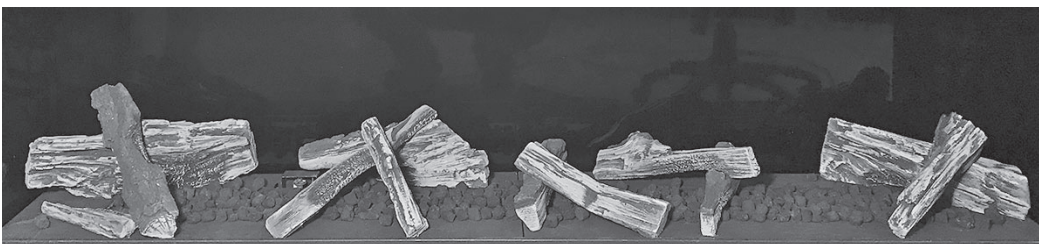

- Place splinters in the embers.

Finished Assembly



IMPORTANT

Approved for use only with the ceramic embers and splinters provided with your Valor fireplace. The use of any other products may void your fireplace warranty.

WARNING

Choking Hazard! Ensure that the fireplace area is clear of embers / splinters as these could be ingested by small children. Vacuum area after installation.

Installation

Fuel Beds

Birch Log Kit 1800BLK

Materials Required

1800BLK Birch Log Kit, which contains:

- 12 Birch logs
- 1 bag of grey splinters
- 1 bag of mixed grey embers
- 2-piece metal platform



Note each log is stamped with its number only on the bottom to identify it.

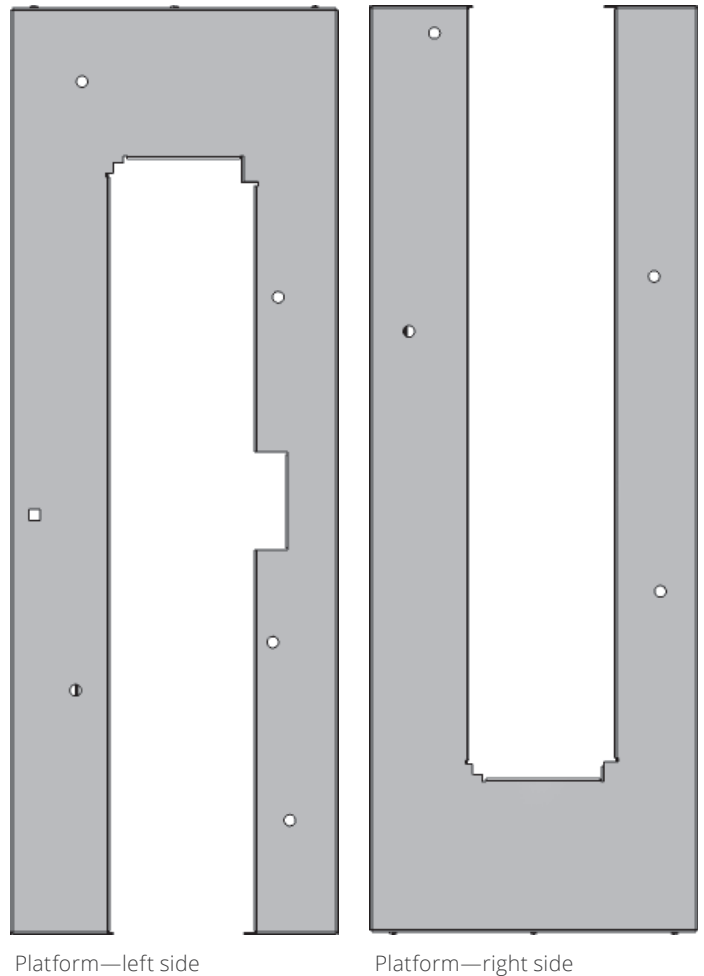

Installation

The following instructions show the best positions for the logs and other pieces to obtain the best fire.

Note that logs that are placed across the burner are above the burner and do not touch it.

1. Place left and right sides platform around the burner as shown (note pilot light cutout). The platform rests in place and is not screwed down. The openings go underside.

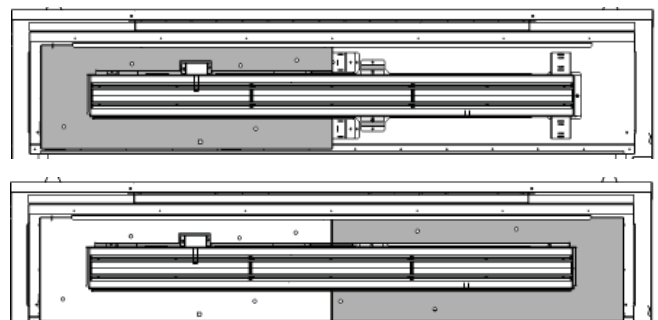

Installation

Fuel Beds

2. Place log L2 with the pin in the hole behind the burner as shown.



3. Place log L1 from top of L2, across the burner to the front of the media tray.



4. Place log L5 with the pin in the hole behind the burner as shown, and the left end just behind the pilot shield.

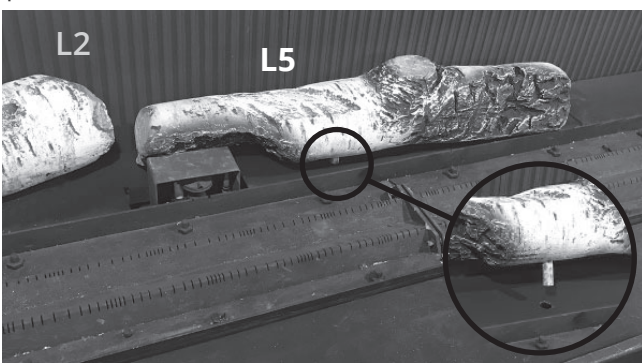

5. Place log L4 from the top of L5, across the burner, to the front of the media tray.

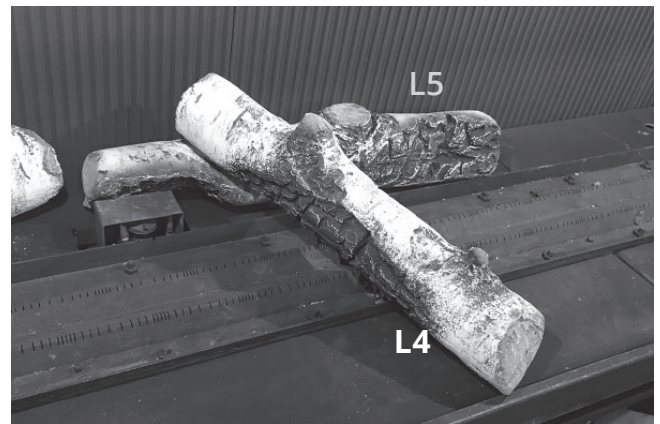

6. Place log L3 on top of L4 and rest it on the front of the media tray.

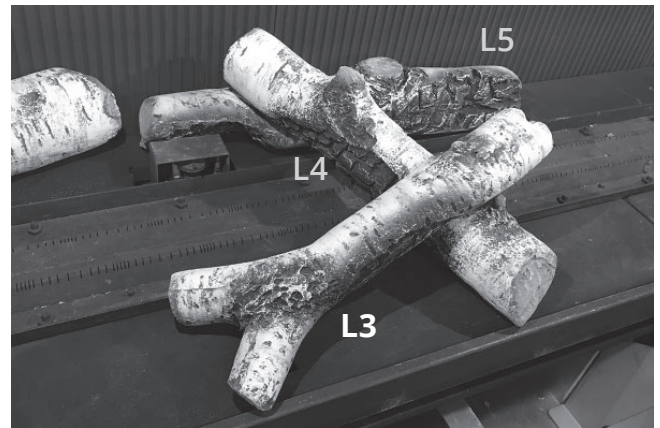

7. Place log L8 with the pin in the hole behind the burner as shown.

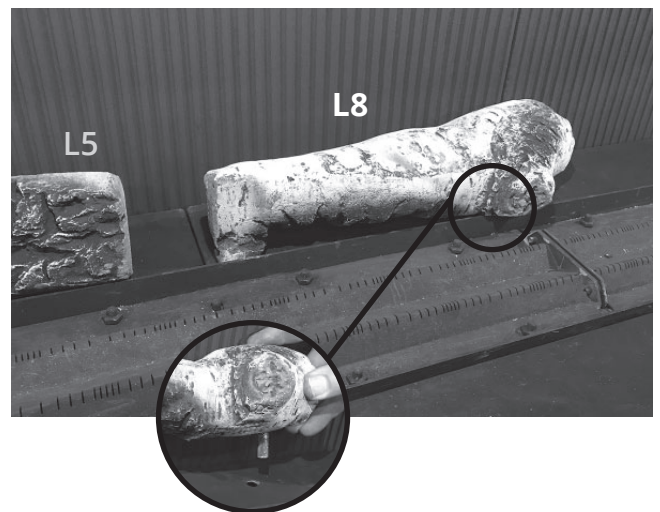

Installation

Fuel Beds

- Place log L7 on top of L8, across the burner, and resting on the front of the media tray.



- Place log L6 on top of L7 and rest it on the front of the media tray.

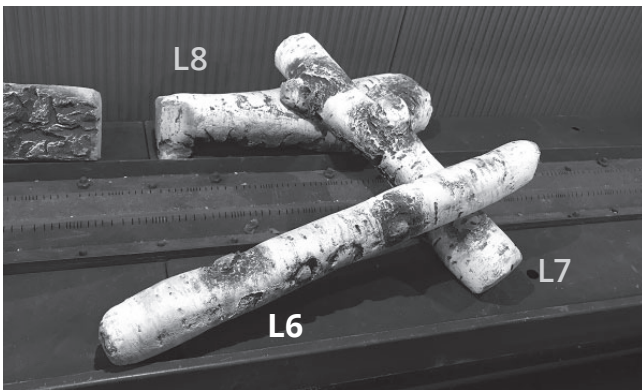

- Place log L9 on the rear media tray as shown. The log can rest just over the edge of the burner.

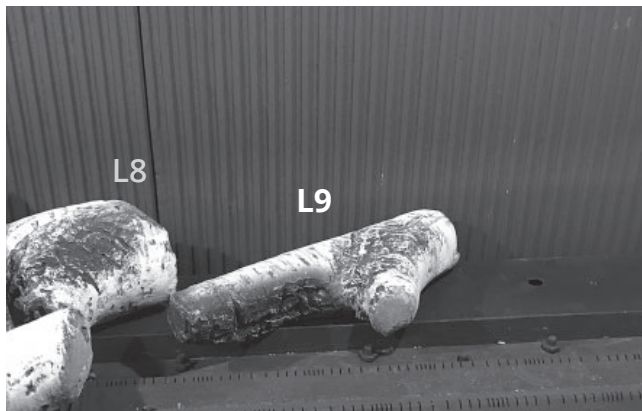

- Place log L11 on the rear media tray as shown.

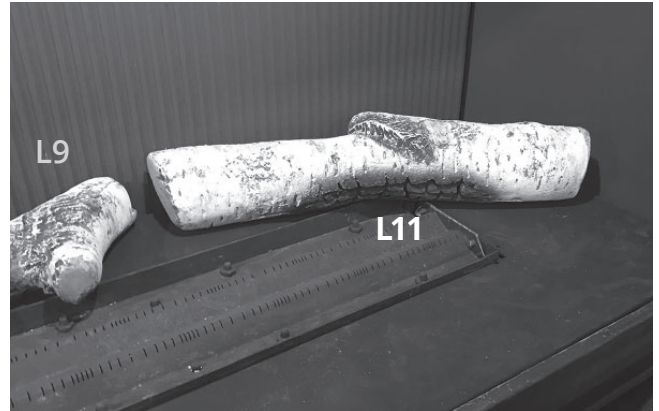

- Place log L10 on top of L11, across the burner, and resting on the front of the media tray.

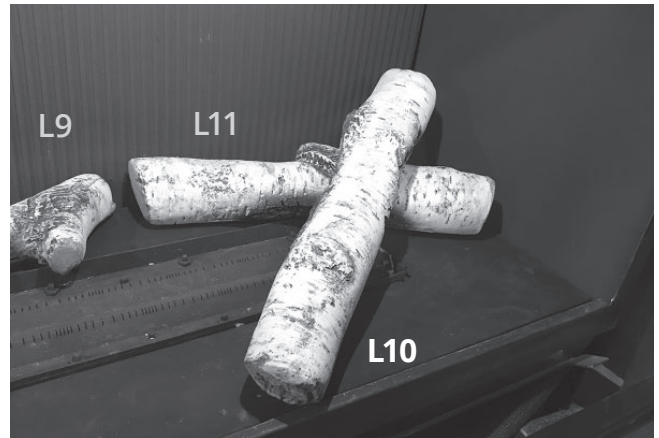

- Place log L12 on the front of the media tray as shown.



Installation

Fuel Beds

14. Place embers and then splinters by hand (do not pour embers as the bag contains dust particles that could block the burner ports) and cover the burner. The embers can be placed onto the front media tray as well if preferred.

Finished Assembly

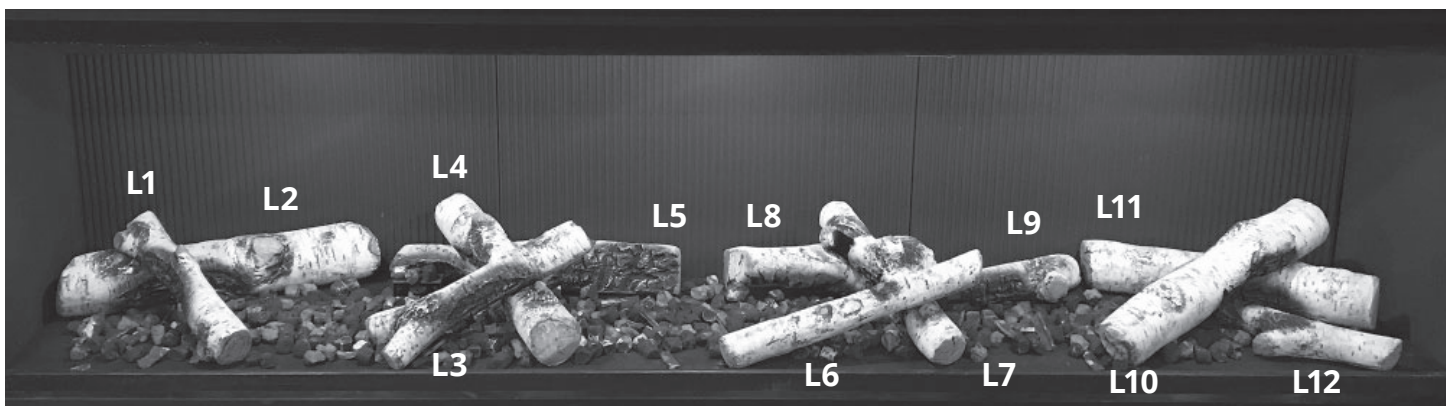

IMPORTANT

Approved for use only with the ceramic embers and splinters provided with your Valor fireplace. The use of any other products may void your fireplace warranty.

WARNING

Choking Hazard! Ensure that the fireplace area is clear of embers / splinters as these could be ingested by small children. Vacuum area after installation.

Installation

Window Re-Installation & Checking

Refit and Check Window

1. Place the window in its bottom railing. Ensure to remove any vermiculite or glass particles in the railing before installing the window.

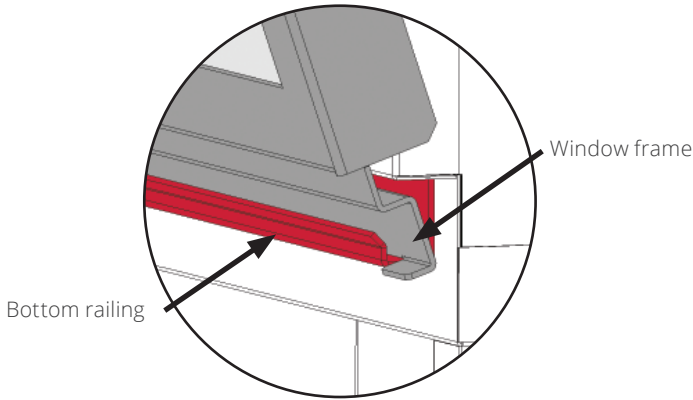

2. Push the top of the window frame against the firebox.

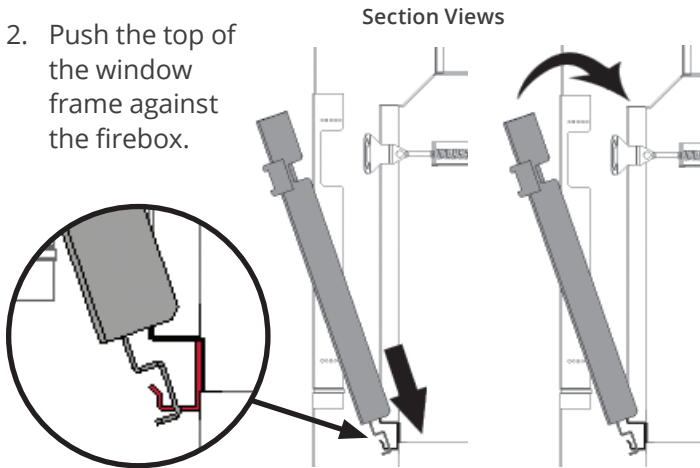

3. While you hold it, pull and hook the side levers back to the window brackets on each side.

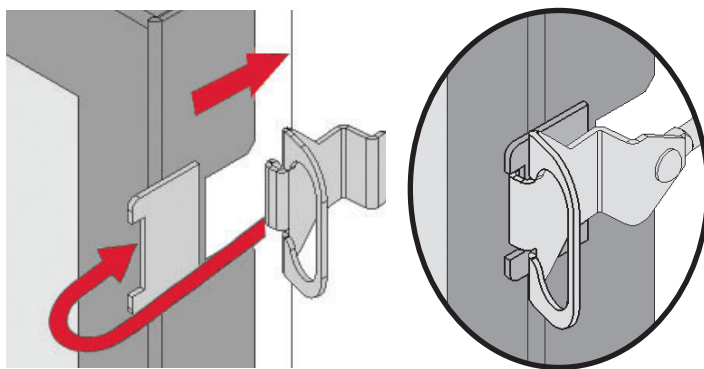

4. Pull out top of window to ensure spring loaded levers work properly.
5. Apply firm hand pressure around the window frame to ensure the window is sealed tight against the firebox.

! WARNING

The window unit must be correctly installed, fastened and sealed after servicing or serious bodily injury and/or damage to the appliance may result.

To ensure a safe operation:

- Double-check that the bottom of the window frame is correctly installed in the bottom support railing;
- Verify that the levers are hooked properly to the window tabs then;
- Pull out the top of the window and release it to insure the springs return it;
- Ensure the window is sealed before operation.

! WARNING

Failure to install the window correctly can:

- Leak carbon monoxide.
- Affect the performance of the fireplace.
- Damage components.
- Cause overheating resulting in dangerous conditions.

Damage caused by incorrect window installation is not covered by the Valor Warranty.

6. If the Hot Glass Warning plate has been removed from the front lower corner of the window, re-install it by sliding it between the glass and the frame as indicated.



! WARNING: EXTREMELY HOT GLASS AND FIREPLACE
Risk of severe burns. Keep Children away from fireplace & controls.
Risque de brûlures graves. Tenir les enfants à l'écart du foyer et des commandes.
AVERTISSEMENT : VITRE ET FOYER EXTREMEMENT CHAUDS



Hot Glass Warning Plate

Installation

Wall Switch

Install Remote Battery and Wall Switch Kit (required)

The Remote Battery and Wall Switch Kit is provided with this appliance. It connects to the receiver in the fireplace.

The receiver is located under the firebox, left of the control valve. It is maintained in position with **Velcro** bands.

1. Pull out the receiver from its location to connect the battery holder and wall switch.
2. Feed the 'white connector end' of the harness assembly through side holes in fireplace liner body to receiver. Ensure sufficient harness length to allow for removal of receiver. Note - coil up any extra harness at fireplace end.
3. Connect switch to auxiliary 5-pin junction and power connection to jack.

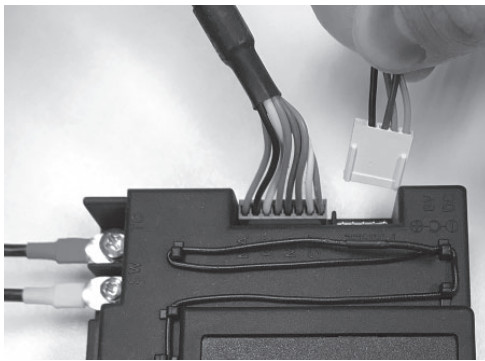

IMPORTANT: The connection can only be done one way.

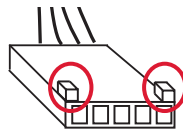

Do not force it or damage the pins on the receiver box!



4. Run harness assembly to mounted position of junction box, securing harness to framing using insulated staples (not included)
5. Feed harness assembly through a restrain on rear of junction box, feeding through until harness sheath is pinched by retainer and providing sufficient length to make connection to rear of switch and battery holder.

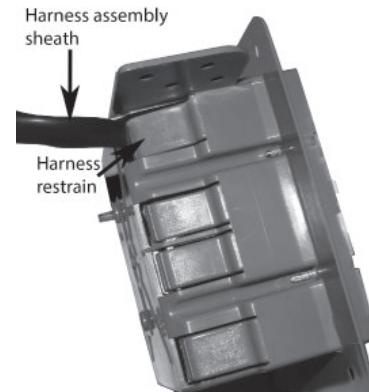

6. Secure junction box to the mounting surface using appropriate fasteners (not included)
7. Align molex connection on switch cable of harness assembly and connect to switch.

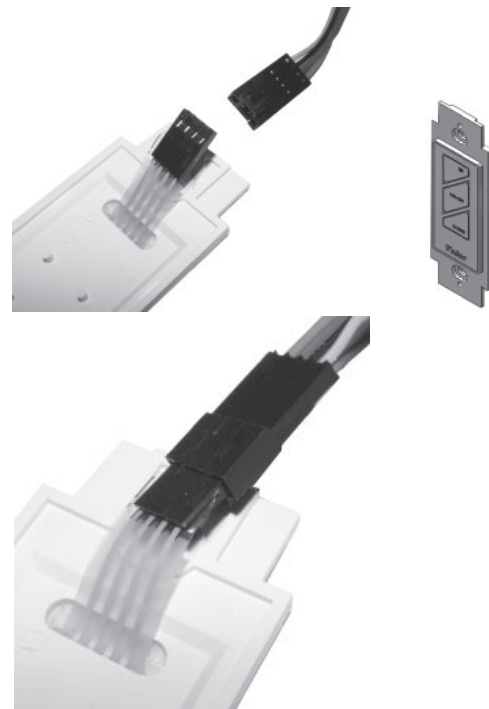

Caution

DO NOT PUT BATTERIES IN THE BATTERY HOLDER until the wires are connected to the burner control unit as short-circuit could result in the destruction of the electrical components.

Do not run the switch wire over the top of the firebox. Route the wire so it does not contact the firebox.

Installation

Wall Switch

8. Mount switch plate to junction box with 2 long screws provided. Note: switch position left or right to suit homeowner wishes.

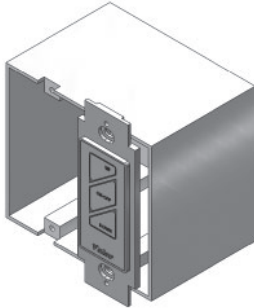

9. Locate and secure magnet plate using 2 'long' screws provided

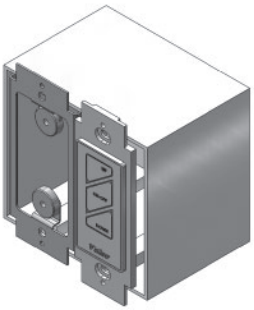

10. Place and secure cover plate to box using 4 screws provided

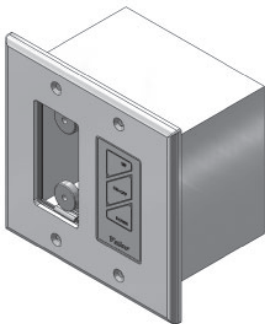

11. Feed cable tie through the 2 side slots of battery cover assembly.
12. Position battery holder to rear face and secure together with cable tie. Note clearance is required for battery snap connection.

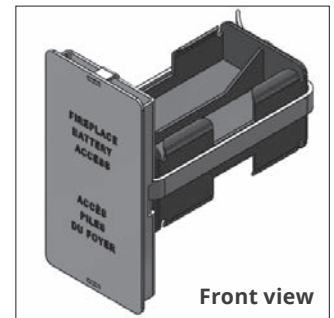
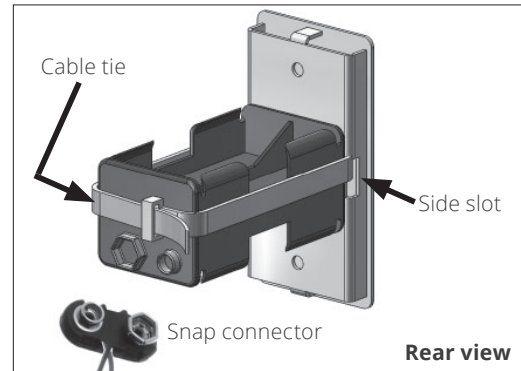

13. Make the snap connection, load 4 AA alkaline batteries into holder (included with fireplace) then feed back into junction box assembly.
- Note: Do not put batteries in the receiver, only in the battery holder by the wall switch.**

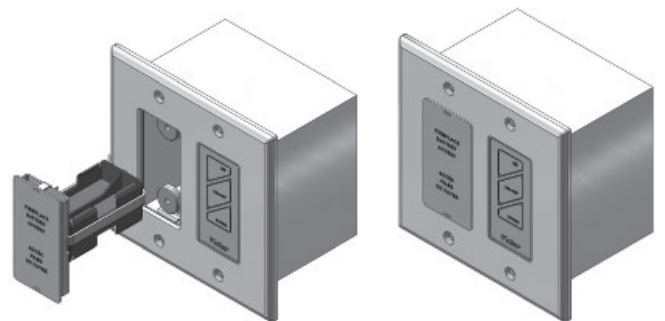

14. Test the operation of the wall switch—see ""Appendix C—Wall Switch Operation"" on page 66.

Caution

DO NOT USE a screwdriver or other metallic object to remove the batteries from the battery holder or the handset! This could cause a short circuit to the receiver.

To avoid short-circuit to the receiver, position the antenna so that it DOES NOT TOUCH the ignition wire.

Installation

Radio Frequency

918.0 MHz for USA and Canada.

This device complies with Part 15 of the FCC Rules and with Industry Canada license-exempt RSS standard(s). Operation is subject to the following two conditions:

- (1) this device may not cause harmful interference, and
- (2) this device must accept any interference received, including interference that may cause undesired operation.

Remote Control Initial Pairing

The receiver and the handset of the remote control system must be initially paired before the first use. (Note that batteries must already be installed in the wall mounted battery holder)

1. Insert two 1.5 V AAA **alkaline** batteries in the handset.
2. Locate the Reset button on the front side of the receiver.
3. With a thin object, press and hold the receiver's RESET button until you hear one short and one long beeps. After the second beep, release the reset button.
4. Within the subsequent 20 seconds, press and hold the  button on the remote handset for 2-3 seconds. **CONN** will be displayed and flash on the handset during the pairing sequence. The handset will count up from 1 to 8, and you will hear two short beeps confirming the pairing is done.

If you hear one long beep, the pairing sequence has failed or the wiring is incorrect.

This is a one time pairing only and is not required when changing the batteries of the handset or battery holder. The remote control system is now ready to use.

Remote Control Pairing

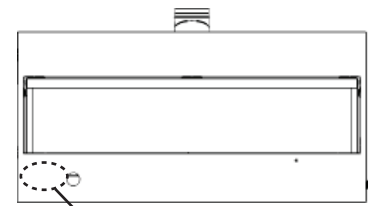
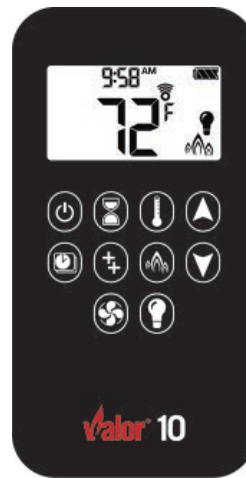

Receiver behind front panel, left of gas valve

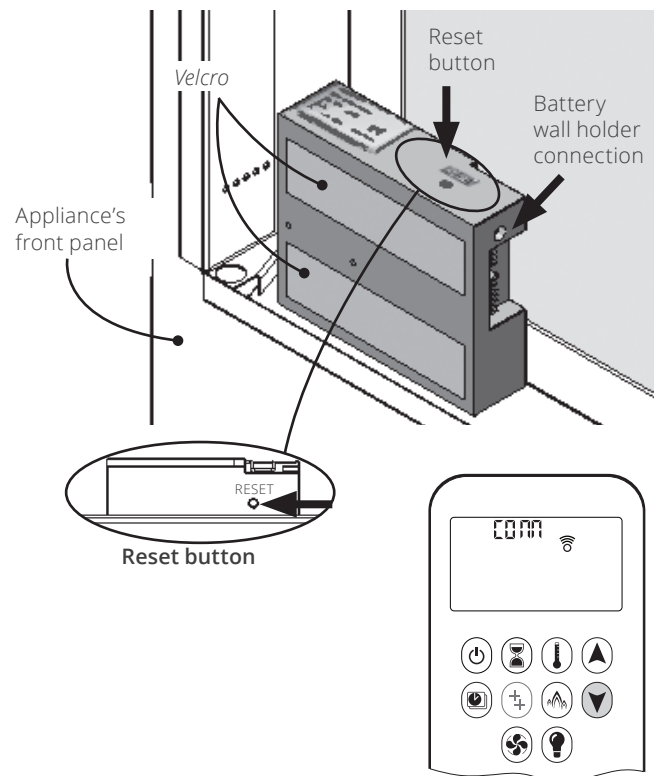

Installation

Remote Control Pairing

Install Remote Control Handset Wall Holder

The remote control kit for this fireplace comes complete with a wall-mounted holder. This holder is not required in all installations but is provided as an optional feature for those customers who wish to mount the remote handset to the wall.



To install the holder to the wall, find a convenient location and use the hardware provided with the kit. Cover the screws with the included caps to finish the mounting.

Once mounted, the holder is magnetic - simply place the remote gently into the holder.

IMPORTANT: The location of the remote control handset is important to assure proper temperature regulation. To obtain a constant temperature, we recommend that the handset should be **between 3 and 15 feet away from the appliance but not directly above it.** We also advise that the handset should be located away from any other heat source and not in direct sunlight as this may affect the temperature sensor located in the remote handset.

Installation

Checking Operation and Aeration

Checking Operation

Turn the fireplace flame up and down using the remote control to confirm that the full range of inputs is achieved—see the remote control operation instructions in “Appendix B—Remote Control Operation” on page 59.

Adjusting Aeration

Light the fire and allow the unit to warm up for 10–15 minutes to evaluate the flame picture. The burner is equipped with an adjustable shutter to control primary aeration. The shutter is factory-set to an aeration gap which will give optimum performance for the vast majority of installations.

Depending of the fuel bed used, altitude and other considerations, the flame picture may be improved by adjusting the aeration. The need for adjustment should be determined only by operating the appliance with the fuel bed, panels and window installed and evaluating the flame picture after a 15-minute warm-up.

Increasing aeration will cause the flames to appear more transparent and blue showing more ceramic effects glow.

Decreasing aeration will cause the flames to appear more yellow or orange showing less ceramic effects glow.

Too little aeration may result in black carbon forming on logs or roof panel and dropping into the firebox. May also result in carbon or soot stains on the vent termination and exterior wall around the termination! The Manufacturer is not responsible for any damage caused by an air shutter setting with too little aeration.

Locating Aeration Control

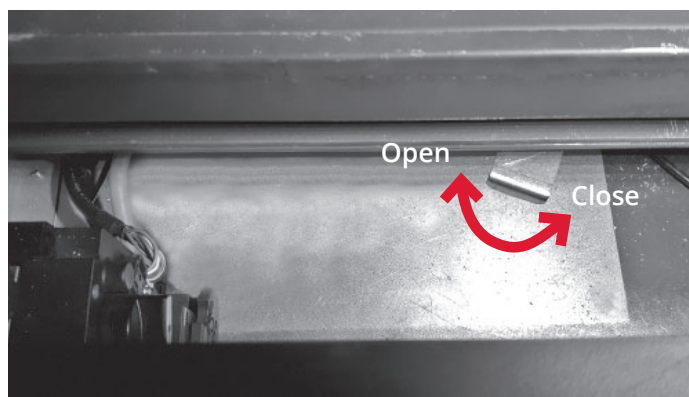
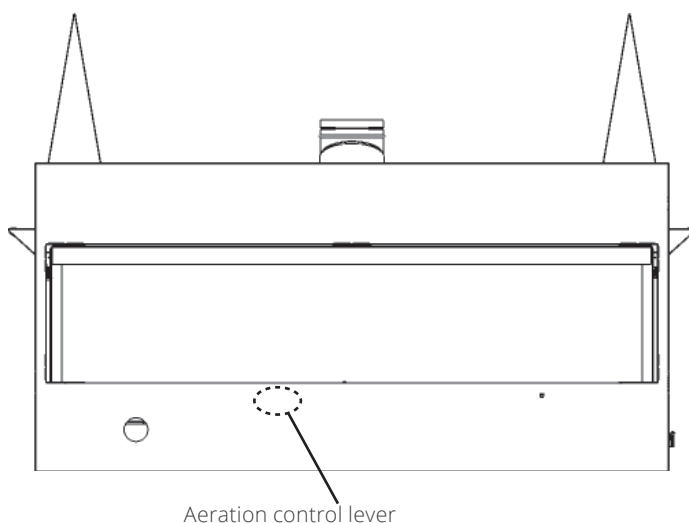

Top view—Air shutter lever located under the firebox behind the front panel

Installation

Trim & Barrier Screen

Install trim plinth support

Install the trim plinth support hooking it vertically on the stiffener bracket, as shown. The stiffener bracket is located just behind the front panel below the window.

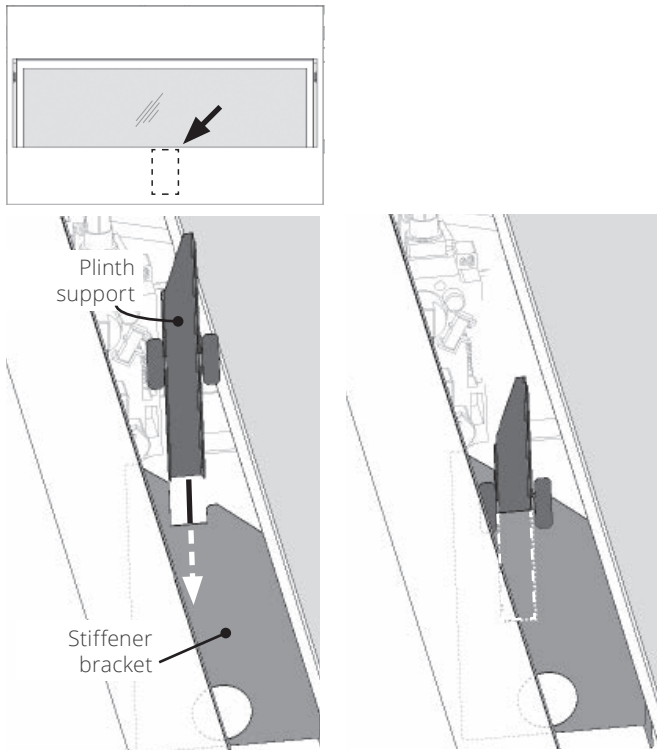

Install Trim and Barrier Screen

Install the trim chosen by the customer for their fireplace. Install as well the barrier screen which is provided with the trim.

Show the customer how to remove the barrier screen to access the controls.

Follow the instructions provided with the trim and leave those instructions behind for the customer's further reference.

1830CIK—Clean Installation Kit

WARNING

HeatShift System MUST be installed on this appliance when using 1830CIK—Clean Installation Kit.

If you are installing the 1830CIK Clean Installation Kit, you need to do it **BEFORE** the cement board.

1. Break off tabs from each corner of the fireplace's front opening (9 tabs, 2 at each corner and 1 more at the top middle). Bend tabs back and forth to break them, or cut them with tin snips as indicated in the kit's installation instructions.

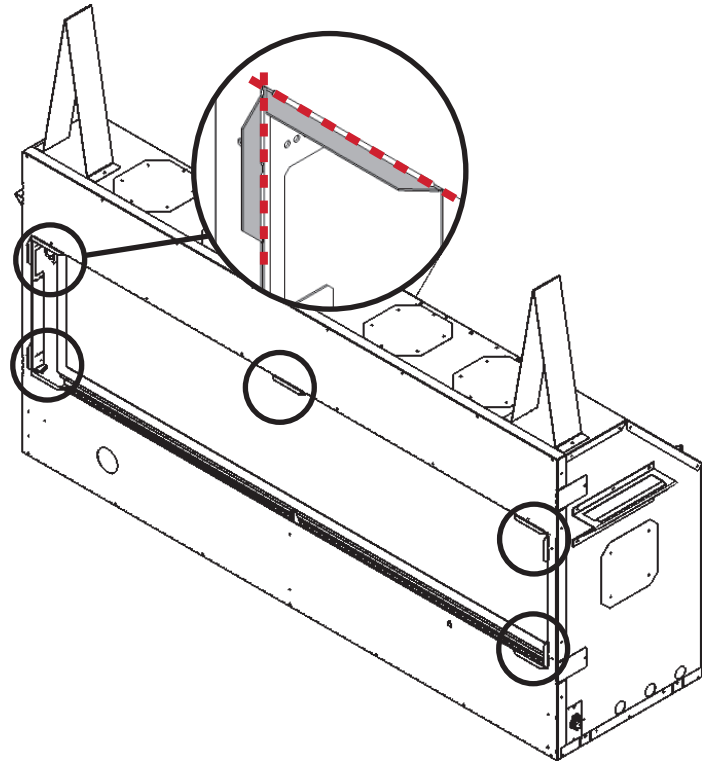

2. Remove the internal convection baffle inside the appliance case, above the firebox. See "Remove Convection Baffle" on page 29 and "Appendix D—HeatShift System" on page 67.

Wiring Diagram

GV60 Wiring Diagram

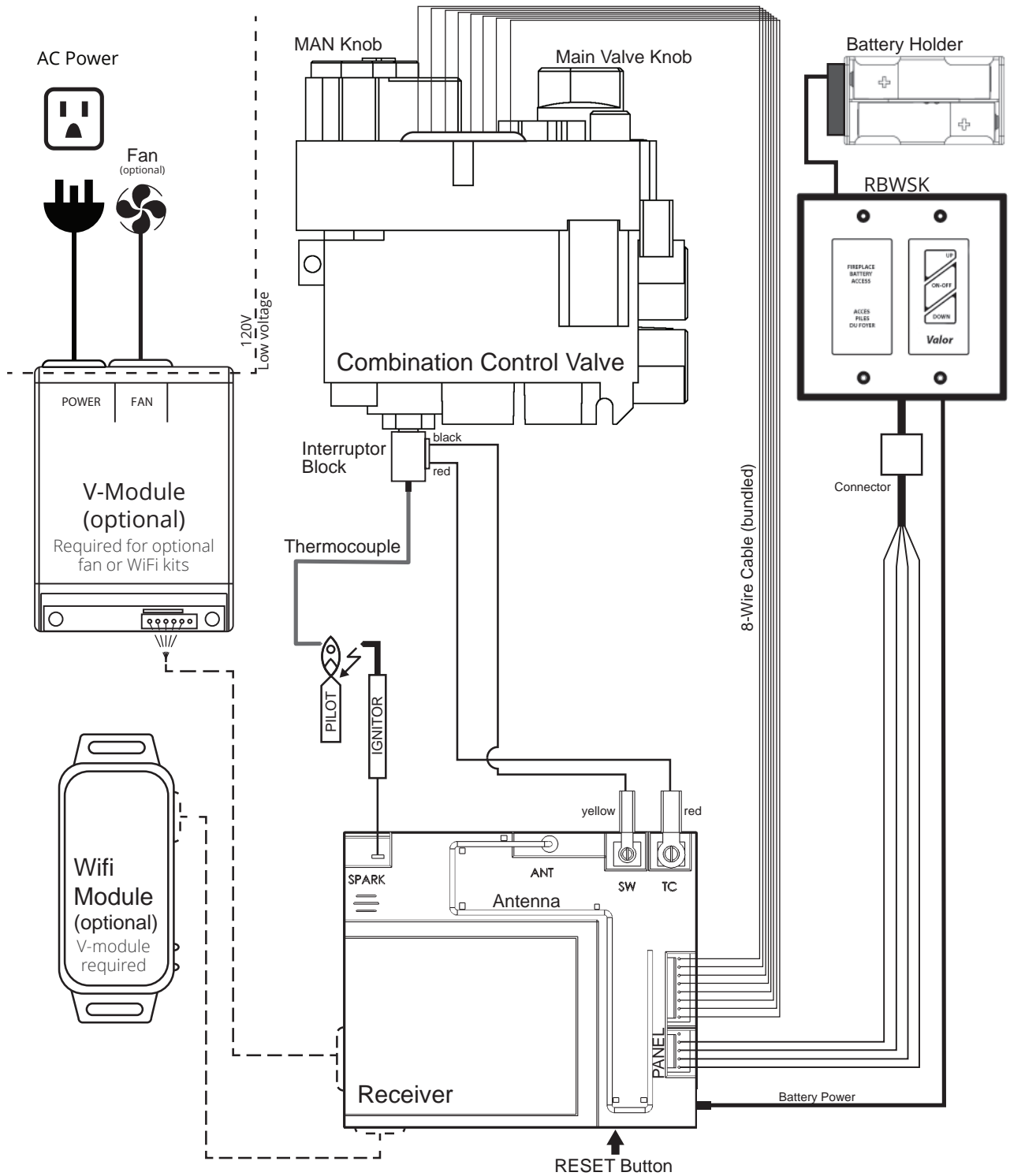

Commonwealth of Massachusetts

State of Massachusetts Carbon Monoxide Detector/Vent Terminal Signage Requirements

For all side wall horizontally vented gas fueled equipment installed in every dwelling, building or structure used in whole or in part for residential purposes, including those owned or operated by the Commonwealth and where the side wall exhaust vent termination is less than seven (7) feet above finished grade in the area of the venting, including but not limited to decks and porches, the following requirements shall be satisfied:

1. INSTALLATION OF CARBON MONOXIDE DETECTORS.

At the time of installation of the side wall horizontal vented gas fueled equipment, the installing plumber or gas fitter shall observe that a hard wired carbon monoxide detector with an alarm and battery back-up is installed on the floor level where the gas equipment is to be installed. In addition, the installing plumber or gas fitter shall observe that a battery operated or hard wired carbon monoxide detector with an alarm is installed on each additional level of the dwelling, building or structure served by the side wall horizontal vented gas fueled equipment. It shall be the responsibility of the property owner to secure the services of qualified licensed professionals for the installation of hard wired carbon monoxide detectors.

a. In the event that the side wall horizontally vented gas fueled equipment is installed in a crawl space or an attic, the hard wired carbon monoxide detector with alarm and battery back-up may be installed on the next adjacent floor level.

b. In the event that the requirements of this subdivision can not be met at the time of completion of installation, the owner shall have a period of thirty (30) days to comply with the above requirements; provided, however, that during said thirty (30) day period, a battery operated carbon monoxide detector with an alarm shall be installed.

2. APPROVED CARBON MONOXIDE DETECTORS. Each carbon monoxide detector as required in accordance with the above provisions shall comply with NFPA 720 and be ANSI/UL 2034 listed and IAS certified.

3. SIGNAGE. A metal or plastic identification plate shall be permanently mounted to the exterior of the building at a minimum height of eight (8) feet above grade directly in line with the exhaust vent terminal for the horizontally vented gas fueled heating appliance or equipment. The sign shall read, in print size no less than one-half (1/2) inch in size, "GAS VENT DIRECTLY BELOW. KEEP CLEAR OF ALL OBSTRUCTIONS".

4. INSPECTION. The state or local gas inspector of the side wall horizontally vented gas fueled equipment shall not approve the installation unless, upon inspection, the inspector observes carbon monoxide detectors and signage installed in accordance with the provisions of 248 CMR 5.08(2)(a)1 through 4.

(b) EXEMPTIONS: The following equipment is exempt from 248 CMR 5.08(2)(a)1 through 4:

1. The equipment listed in Chapter 10 entitled "Equipment Not Required To Be Vented" in the most current edition of NFPA 54 as adopted by the Board; and
2. Product Approved side wall horizontally vented gas fueled equipment installed in a room or structure separate from the dwelling, building or structure used in whole or in part for residential purposes.

Commonwealth of Massachusetts

(c) MANUFACTURER REQUIREMENTS - GAS EQUIPMENT VENTING SYSTEM PROVIDED. When the manufacturer of Product Approved side wall horizontally vented gas equipment provides a venting system design or venting system components with the equipment, the instructions provided by the manufacturer for installation of the equipment and the venting system shall include:

1. Detailed instructions for the installation of the venting system design or the venting system components; and
2. A complete parts list for the venting system design or venting system.

(d) MANUFACTURER REQUIREMENTS - GAS EQUIPMENT VENTING SYSTEM NOT PROVIDED. When the manufacturer of a Product Approved side wall horizontally vented gas fueled equipment does not provide the parts for venting the flue gases, but identifies "special venting systems", the following requirements shall be satisfied by the manufacturer:

1. The referenced "special venting system" instructions shall be included with the appliance or equipment installation instructions; and
2. The "special venting systems" shall be Product Approved by the Board, and the instructions for that system shall include a parts list and detailed installation instructions.

(e) A copy of all installation instructions for all Product Approved side wall horizontally vented gas fueled equipment, all venting instructions, all parts lists for venting instructions, and/or all venting design instructions shall remain with the appliance or equipment at the completion of the installation.

Appendix A—Lighting Instructions



FOR YOUR SAFETY, READ BEFORE LIGHTING

WARNING: If you do not follow these instructions exactly a fire or explosion may result causing property damage, personal injury or loss of life.

- A. This appliance has a pilot which must be lighted by hand or by remote control. Follow these instructions exactly. To save gas, turn the pilot off when not using the appliance for a prolonged period of time.
- B. **BEFORE LIGHTING**, smell all around the appliance area for gas. Be sure to smell next to the floor because some gas are heavier than air and will settle on the floor.
- WHAT TO DO IF YOU SMELL GAS
- Do not try to light any appliance.
 - Do not touch any electric switch; do not use any phone in your building.
 - Immediately call your gas supplier from a neighbor's phone. Follow the gas supplier's instructions.
 - If you cannot reach your gas supplier, **call the fire department**.
- C. Use only your hand to push in or turn the control knobs. Never use tools. If the knobs will not push in or turn by hand, **don't try to repair them; call a qualified service technician. Force or attempted repair may result in a fire or explosion.**
- D. Do not use this appliance if any part has been under water. **Immediately call a qualified service technician to inspect the appliance and to replace any part of the control system and any gas control, which has been under water.**

LIGHTING INSTRUCTIONS

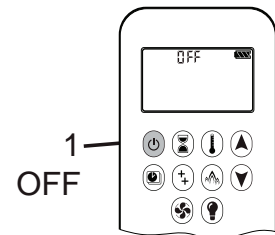
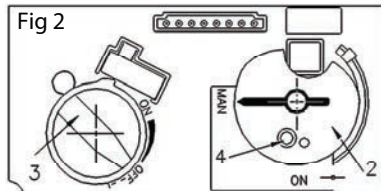
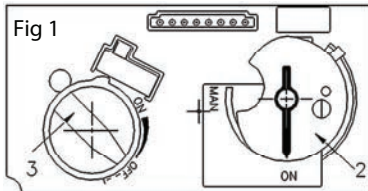

1. STOP! Read the safety information above
2. TO CLEAR ANY GAS, turn main valve off by pressing the button on remote handset (1). Wait five (5) minutes to clear out any gas, then smell for gas, including near the floor. If you smell gas, STOP! follow "B" in the safety information above on this label. If you don't smell gas, go to the next step.
3. AUTOMATIC IGNITION: MAN-knob (2) in ON position. Ensure Flame Adjustment knob (3) is set to lowest setting (Fig. 1). Locate the pilot (Fig. 3.) inside the firebox.

On the remote control handset, press the button; a short acoustic signal confirms the start has begun. Further short acoustic signals indicate the ignition process is in progress. When the pilot is lit, the Flame Adjustment knob (3) will automatically rotate to the highest setting. Press the button on the remote control handset to reduce the flame height.

4. MANUAL IGNITION: MAN-knob (2) in MAN position (Fig. 2).
With the window off, locate the pilot (Fig. 3) inside the firebox. Set Flame Adjustment knob (3) to the lowest setting. Push down the metallic core (4) with a pen or similar instrument; this will establish the pilot gas flow. Light gas at the pilot (5) with a match. Continue holding down metal core (4) for about 10 seconds; after release, pilot should remain lit. If the pilot will not stay lit after several tries, turn the gas control knob (3) to OFF and call your local service technician or gas supplier. Reinstall the window and set the MAN-knob (2) to ON; turn Flame Adjustment knob (3) up or down manually or use the and buttons on the remote control handset to adjust the flame height.

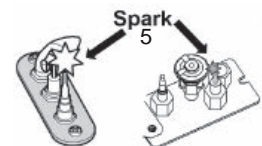

Fig 3

TO TURN OFF GAS TO APPLIANCE

AUTOMATIC SHUT-OFF (using the remote control handset):
Press and hold the button on the remote control handset to shut-off the main burner gas flow.
Press the button on remote handset to shut-off the appliance, including pilot flame.

Appendix B—Remote Control Operation

Initial Pairing

Before the remote control can be used with the fireplace, it must be paired. See page 51.

Main Display and Remote Handset

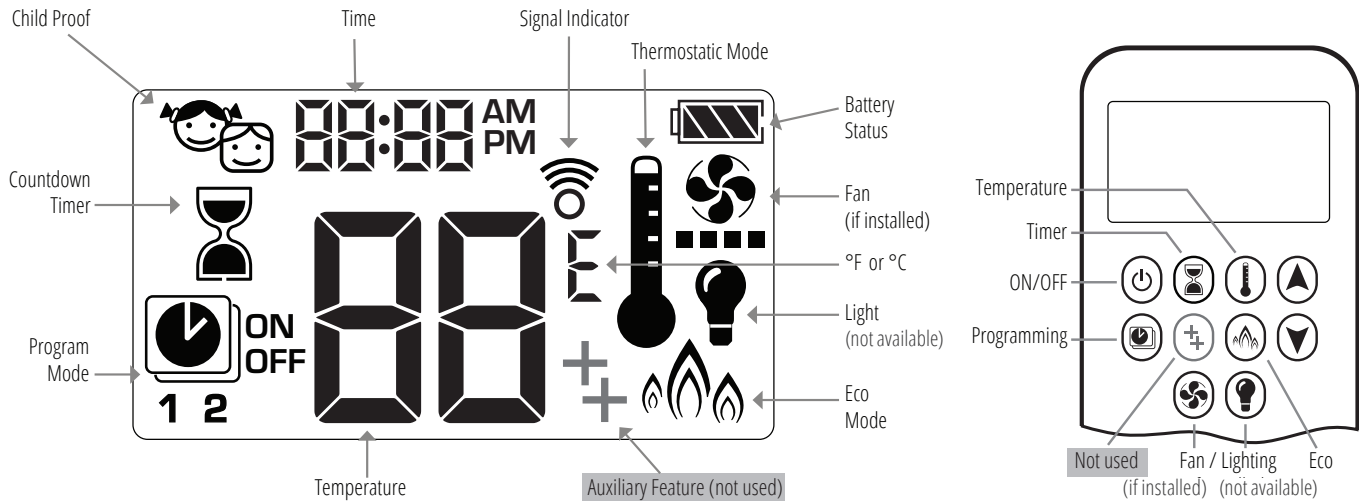

To Turn On Fire

NOTE: When pilot ignition is confirmed, motor automatically turns to maximum flame height.

One-Button lighting (default):

Two-Button lighting: + simultaneously

Press and hold for 4 seconds, until 8 short beeps and a blinking series of lines confirms the start sequence has begun. Release button.

Main gas flows once pilot ignition is confirmed.

Handset automatically goes into manual mode after main burner ignition.

Standby Mode (Pilot Flame)

Press and hold to set appliance to pilot flame.

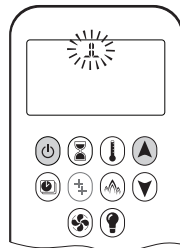
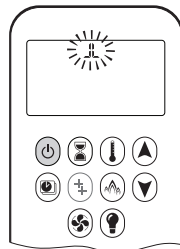

CAUTION: If the pilot does not stay lit after several tries call your local service technician or gas supplier.

To Turn Off Fire

Press to turn OFF.

Note: There is a 2 minute delay after switching off before the next ignition is possible.



CAUTION: Always check the fire and pilot visually to ensure they are off.

Flame Height Adjustment

To increase flame height, press and hold .

To decrease flame height, press and hold . You may hold the button down until the fire is set to pilot flame only.

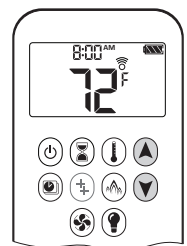



Appendix B—Remote Control Operation

Designated Low Fire and High Fire

To go to low fire, double-click . "LO" is displayed.

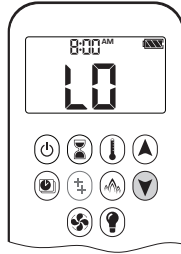
Note: Flame goes to high fire first before going to low fire.



To go to high fire, double-click . "HI" is displayed.

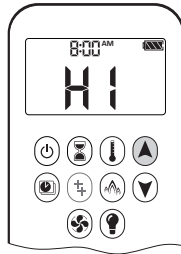

Choosing 1-Button or 2-Button Ignition

On the remote control handset, you can choose a 1-button or 2-button ignition. You can also choose to activate or deactivate some of the functions. By default, the handset is set to a 1-button ignition.



To change from 1-button to 2-button ignition, remove the batteries, wait 10 seconds, reinsert batteries, and immediately when the display flashes, press and hold the  button for 10 seconds. **ON** is displayed and **1** is flashing. When change is complete, **1** changes to **2**.

To change from 2-button to 1-button ignition, proceed the same as above. **ON** is displayed and **2** is flashing. When change is complete, **2** changes to **1**.

Deactivating or Activating Functions

These functions are active by default, but can be deactivated at any time:

- Child Proof
- Program Mode
- Thermostatic Mode
- Eco Mode
- Circulating Fan Operation
- Countdown Timer

 **NOTE:** The function Auxiliary Feature  is not used.

To deactivate functions:

1. Install batteries. All icons are displayed and flashing.
2. While the icons are flashing, press the relevant function button and hold for 10 seconds.
3. The function icon will flash until deactivation is complete. Deactivation is complete when the function icon and two horizontal bars () are displayed.

Note: If a deactivated button is pressed, there is no function, and the two horizontal bars are displayed.

To activate functions:

1. Install batteries. All icons are displayed and flashing.
2. While the icons are flashing, press the relevant function button and hold for 10 seconds.
3. The function icon will continue to flash until activation is complete, and then turn solid. Activation is complete when the function icon is displayed.















Setting Celsius or Fahrenheit

To change between °C and °F, press and hold  +  simultaneously.

Note : °C = 24-hour clock
°F = 12-hour clock



Setting the Time

1. Press  +  simultaneously. **Day** flashes.
2. Press  +  to select a number to correspond with the day of the week.
 - 1 = Monday
 - 2 = Tuesday
 - 3 = Wednesday
 - 4 = Thursday
 - 5 = Friday
 - 6 = Saturday
 - 7 = Sunday
3. Press  +  simultaneously. **Hour** flashes.
4. To select hour press  or .
5. Press  +  simultaneously. **Minutes** flash.
6. To select minutes press  or .
7. To confirm, press  +  simultaneously or wait.

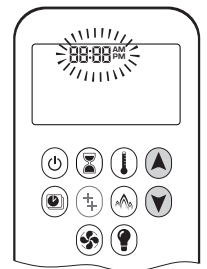

Appendix B—Remote Control Operation

Child Proof

Your handset can be set to lock out all commands to the fireplace, except OFF.

To turn Child Proof ON:

1. Press and hold + simultaneously.
2. is displayed. Child Proof is now active.

To turn Child Proof OFF:

1. Press and hold + simultaneously.
2. disappears. Child Proof is now inactive, and the handset has full function.

Countdown Timer

You can set your fireplace to automatically turn off at the end of a timer.

To set a Countdown Timer:

1. Press and hold until is displayed.
Hour flashes.
2. Press or to select Hour.
3. To confirm, press .
- Minutes** flash.
4. Press or to select Minutes.
5. To confirm, press or wait.

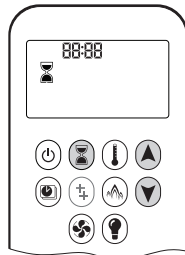

To turn off a Countdown Timer:

1. Press , and the countdown disappears.

Note: The Countdown Timer only works in Manual, Thermostatic, and Eco modes. Maximum countdown time is 9 hours and 50 minutes.

Light/Dimmer Operation (not available)

Circulating Fan Operation (if installed)

Setting:

1. Press and hold until flashes.
2. Press to increase or to decrease fan speed.
3. To confirm setting, either press or wait. is displayed.

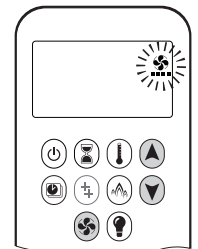

Off:

Press until all 4 speed level bars disappear.

Note: When setting, if the fan was not switched off after last use, it starts automatically 4 minutes after ignition at maximum speed, and goes to the last set level after 10 seconds. The fan stops 10 minutes after the gas is OFF or at pilot.

Appendix B—Remote Control Operation

Modes of Operation

Thermostatic Mode

The room temperature is measured and compared to the set temperature. The flame height is automatically adjusted to achieve the set temperature.

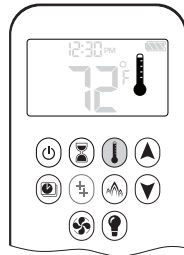

Program Mode

The temperature is controlled by Programs 1 and 2, each of which can be set to go on and off at specific times, at a set temperature.



Eco Mode

Flame height modulates between high and low. If the room temperature is lower than the set temperature, the flame height stays on high for a longer period of time. If the room temperature is higher than the set temperature, the flame height stays on low for a longer period of time. One cycle lasts approximately 20 minutes.





 If any of the above modes (Thermostatic, Program, or Eco) are engaged by the MyFire app over WiFi, the handset will display **APP**.

Manual Mode

The on/off status of the fireplace, as well as flame height, are manually controlled by the user.





Thermostatic Mode

On:

Press .  is displayed. Preset temperature displays briefly, followed by the room temperature.





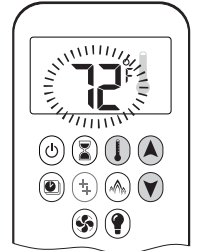

Setting Desired Temperature:

1. Press and hold  until  is displayed and set temperature flashes.
2. To adjust set temperature, press  or .
3. To confirm, press  or wait.



Off:

1. Press .
2. Press  or  to go to Manual Mode.
3. Press  to go to Program Mode.
4. Press  to go to Eco Mode.





Program Mode

On:

Press .
, 1 or 2, ON or OFF are displayed.





Off:

1. Press , , or  to go to Manual Mode.
2. Press  to go to Thermostatic Mode.
3. Press  to go to Eco Mode.

Note: The set temperature for Thermostatic Mode is the temperature for the ON time in Program Mode. Changing the Thermostatic Mode set temperature also changes the ON time temperature in Program Mode.

Default Settings:

- ON TIME (Thermostatic) TEMPERATURE: 70°F / 21°C
- OFF TIME TEMPERATURE: “ ” (pilot flame only)

Appendix B—Remote Control Operation

Temperature Setting:

1. Press and hold until flashes. **ON** and set temperature (set in Thermostatic Mode) is displayed.
2. To continue, press or wait. **OFF** displayed, temperature flashes.
3. Select off temperature by pressing or .
4. To confirm, press .

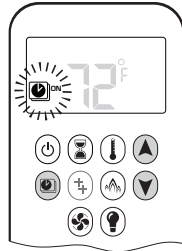

Note: The on (Thermostatic) and off set temperatures are the same for each day.

Day Setting:

1. **ALL** flashes. Press or to choose between:
 - **ALL** = same settings ON-OFF every day
 - **SA:SU** = same settings ON-OFF Saturday and Sunday
 - **1, 2, 3, 4, 5, 6, 7** = daily timer—unique ON-OFF settings for a single day of the week, for multiple days of the week or for every day of the week.
2. To confirm, press .

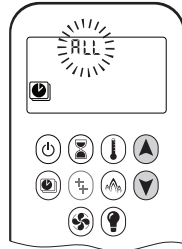

ALL Selected (same settings every day)

On Time Setting (PROGRAM 1)

1. **1, ON** are displayed. **ALL** is displayed briefly. Hour flashes.
2. To select hour, press or .
3. To confirm, press . **1, ON** are displayed. **ALL** displayed briefly. Minutes flash.
4. To select minutes, press or .
5. To confirm, press .

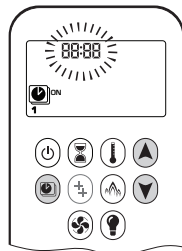

Off Time Setting (PROGRAM 1)

1. **1, OFF** are displayed. **ALL** is displayed briefly. Hour flashes.
2. To select hour, press or .
3. To confirm, press . **1, OFF** are displayed. **ALL** displayed briefly. Minutes flash.
4. To select minutes, press or .
5. To confirm, press .

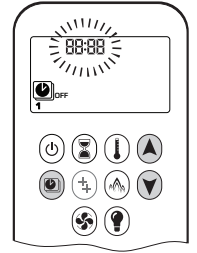

Note: Either continue to PROGRAM 2 and set ON and OFF times or stop programming at this point, and PROGRAM 2 remains deactivated.

Note: PROGRAM 1 and 2 use the same ON (Thermostatic) and OFF temperatures. Once a new ON (Thermostatic) and/or OFF temperature has been set, that temperature becomes the new default setting.

Note: ON and OFF times programmed for PROGRAM 1 and PROGRAM 2 become the new default times.

The batteries must be removed to clear the PROGRAM 1 and PROGRAM 2 ON and OFF times and temperatures.

SA:SU (same settings Saturday and Sunday) or 1, 2, 3, 4, 5, 6, 7 (different settings on different days)

- Set on time and off time using the same procedure as "ALL Selected" above.
- Waiting to finish setting.

Eco Mode

On:

Press button to enter Eco Mode. is displayed.

Flame height modulates between high and low every 20 minutes.

Off:

Press button to exit Eco Mode. disappears.



Appendix B—Remote Control Operation

Low Battery Indication

 **CAUTION:** Do not use a screwdriver or other metallic object to remove the batteries from the battery holder or the handset. This could cause a short circuit.

Handset

The battery icon  will show when the battery needs to be replaced. Replace with two 1.5 V AAA alkaline batteries.

Receiver

Frequent beeps for 3 seconds when the motor turns indicate the batteries in the battery holder need to be replaced. Replace with four 1.5 V AA alkaline batteries.

Automatic Shut Off

Countdown Timer

At the end of countdown time period, the fire turns off. The Countdown Timer only works in Manual, Thermostatic, and Eco Modes. Maximum countdown time is 9 hours and 50 minutes.

Low Battery Receiver

With low battery power in the battery holder, the system shuts off the fire completely. (This will not happen if the power is completely interrupted.)

Seven Day Shut Off

The system shuts off the fire completely if there is no change in flame height for 7 days.

Automatic Turn Down

3 Hour No Communication Function

The valve will turn to pilot flame if there is no communication between the handset and receiver for a 3-hour period. The fire will continue to function normally when communication is restored.

Appendix B—Remote Control Operation

Error Codes

In the event of an error condition with the handset or fireplace, the handset will display an error code.

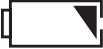
Failure Code	Message on Handset	Duration of Display	Symptom	Possible Cause
F04	F04	4 sec	<ul style="list-style-type: none"> No pilot flame within 30 sec Note: after 3 failed ignition sequences, F06 shown 	<ul style="list-style-type: none"> No gas supply Air in pilot supply line No spark Reversed polarity in thermocouple wiring
F06	F06	4 sec	<ul style="list-style-type: none"> 3 failed ignition sequences in 5 minutes Fire is not responding, no pilot flame 	<ul style="list-style-type: none"> No gas supply Air in pilot supply line No spark Reversed polarity in thermocouple wiring Incorrect pilot orifice if valve has been converted from LPG to NG or vice versa
F07	Low battery symbol 	Permanent	<ul style="list-style-type: none"> Battery icon flashes on handset display 	<ul style="list-style-type: none"> Low battery in handset
F09	F09	4 sec	<ul style="list-style-type: none"> Fire is not responding No electronic control of fire 	<ul style="list-style-type: none"> Down arrow button (▼) was not pressed during pairing Receiver and handset are not synced
F46	F46	4 sec	<ul style="list-style-type: none"> Fire is not responding Intermittent response No electronic control of fire 	<ul style="list-style-type: none"> No or bad connection between receiver and handset No power at receiver (batteries low) Low communication range (mains adapter faulty, handset not communicating with receiver)

Appendix C—Wall Switch Operation

The Wall Switch can be used to control your fireplace. You can turn the pilot on or off and you can increase or decrease the flame height.

Note that the thermostat and programming functions are not available with the wall switch.



Adjusting Flame Height

Press and hold large flame  button to gradually increase flame height.

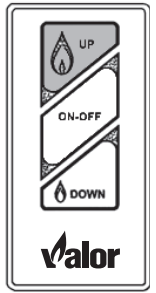

Turning Appliance ON and OFF

Press ON-OFF button once to light pilot. Press again to shut off pilot.

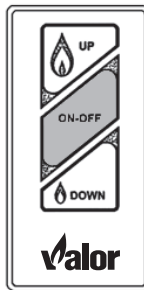

Press and hold small flame  button to gradually decrease flame height.

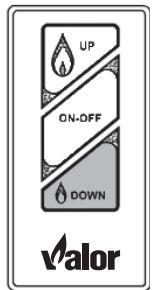

Appendix D—HeatShift System

HeatShift™ System

Planning Installation: Linear with HeatShift™

Instructions for use with the following **Valor Heater Models: 1500, 1600, 1700 and 1800 J or K**
Incompatible with earlier models: 1500I, 1600I, and 1700I

Application

The HeatShift™ system redistributes the warm air flow away from the fireplace opening to a more desirable location using natural convection without use of a fan.

Plenums LKD1, LDK3, LDK4 or LDK9: the warm air flow is relocated to a position higher up the wall, out the sidewalls, or even to an adjacent room.

Termination Plates LDK7: the warm air flow is discharged through a gap (min. 2-1/2" [64 mm]) between the wall above the fireplace and the ceiling.

LDK7's discharge opening must be located in the same room as the fireplace.

The result is much cooler wall temperatures above the fireplace opening for locating televisions, artwork, etc.

The 1595CFK or 1595CFKV2 Circulating Fan Kit are not recommended when installing the HeatShift system.

Any kit, LDK1, LDK3, LDK4, LDK7 or LDK9 may be used with compatible model fireplaces L1, L2 or L3 listed above.

As a further option, the warm airflow may be extracted away from the duct kit plenum (**LDK1 and LDK4 ONLY**) by connecting a 1270RBK HeatSplit Remote Blower Kit to the duct kit plenum.

This kit is compatible with the listed fireplaces only. Earlier version fireplaces will not accept the addition of this kit.

Note: These instructions are to be used in conjunction with instructions regarding fireplace installation in this manual.



WARNING

All fireplaces listed above require the removal of the internal convection baffle for this system to function properly—read instructions carefully!

The use of this kit will permit lower mantel clearances to be used—see *Combustible Mantel Clearances* in this Appendix. These lower mantel clearances **must ONLY be used when the HeatShift system is installed and the internal convection baffle has been removed.**

Approvals

The LDK1, LDK3, LDK4, LDK7 and LDK9 duct kits are CSA approved for use only with Valor Series fireplaces listed above—DO NOT use with any other models.

This HeatShift system may also be used to reduce wall surface temperatures on approved outdoor installations.

5-inch [127 mm] diameter duct used with this kit must be metal and meet requirements of UL-181 Class 1 Air Duct. Flexible aluminum duct is acceptable provided it meets the UL-181 Class 1 requirements.



WARNING

DO NOT cover or place objects in front of or on top of air outlet(s). AVOID locating outlet within 7 feet [2134 mm] above floor level as discharge temperatures are hot!



WARNING

When placing discharge close to ceilings, staining or streaking may occur on light colored ceilings due to any dust, etc. in air flow; placing plenum(s) lower on the wall will help reduce the possibility of staining or streaking.

Appendix D—HeatShift System

Kits

There are 5 kits to choose from:

- LDK1— Plenum, 48" [1220 mm]
- LDK3— Plenums (2), includes grilles, 14" [356 mm]
- LDK4— Plenum, 38" [966 mm]
- LDK7— Duct Termination Plates (2)—for wall valance discharge ONLY
- LDK9— Plenum, 30" [762 mm]

Kits Contents

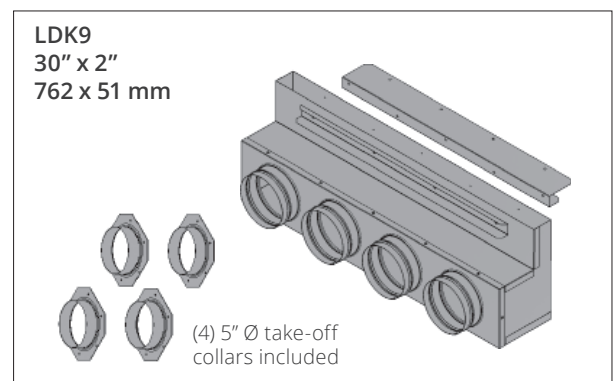
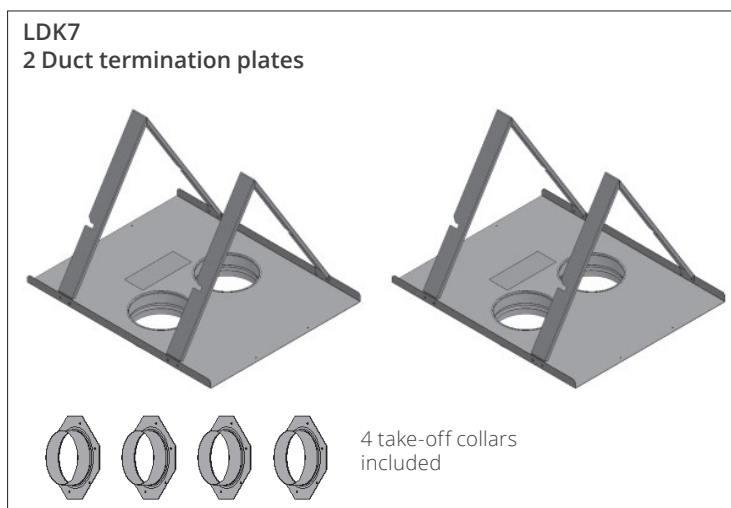
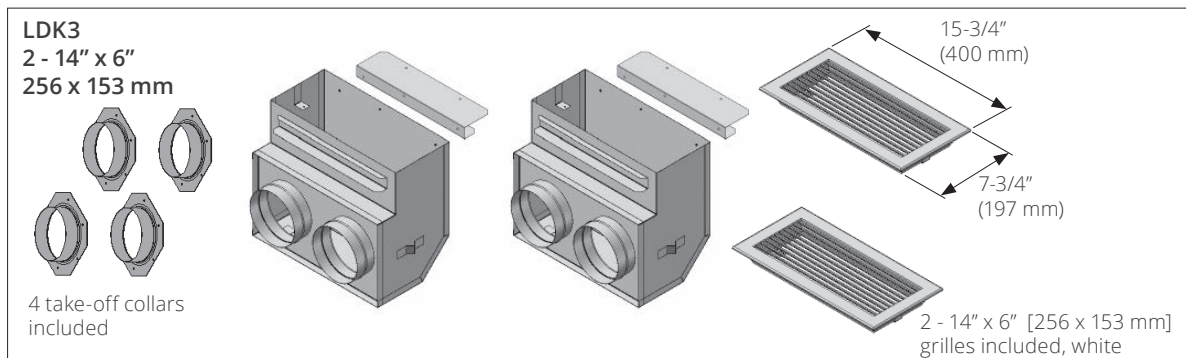
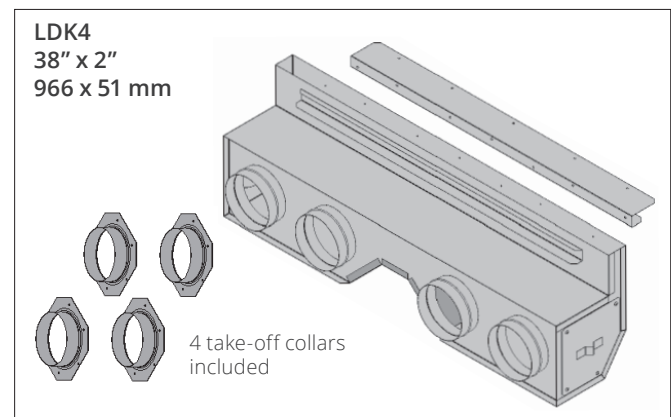
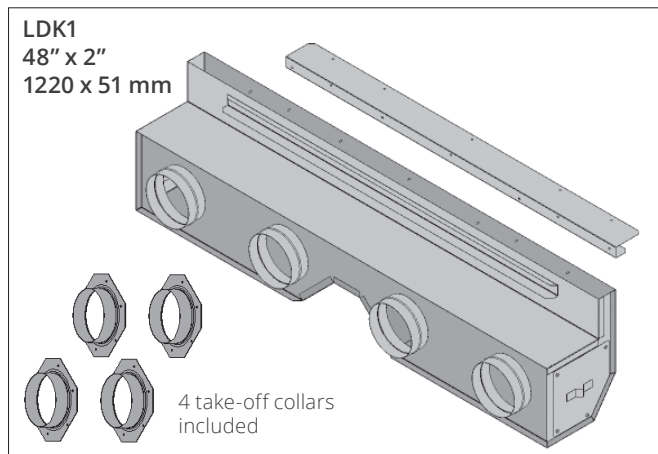

Appendix D—HeatShift System

Optional accessories

- LDK2—48" [1220 mm] Finishing Frame, to use with LDK1
- LDK5—38" [966 mm] Finishing Frame, to use with LDK4
- LDK6— 5" [127 mm] dia Aluminum 2-ply Flex Kit—
2 x 10'-0" [3048 mm] lengths, may be cut to required length
- LDK10—30" [732 mm] Finishing Frame, to use with LDK9

Kits Contents

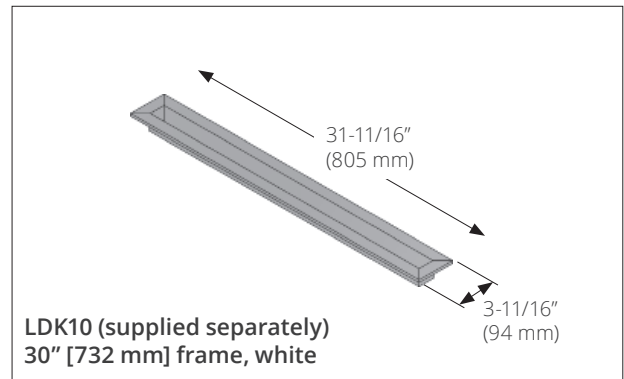
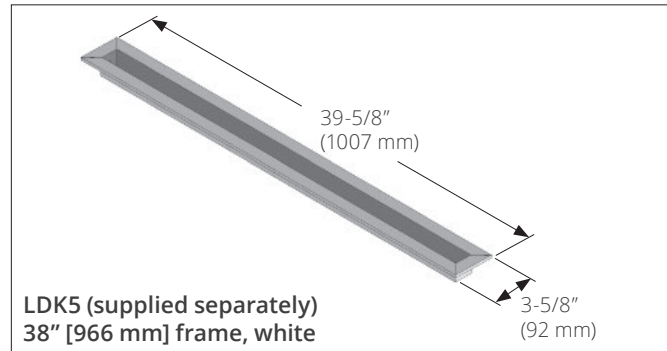
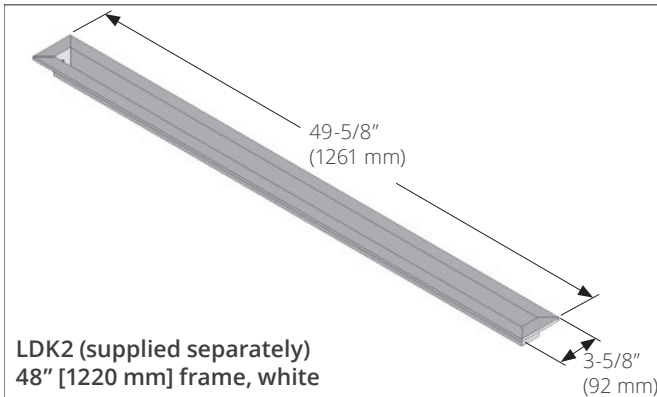

Appendix D—HeatShift System

Suggested Configurations Not to scale

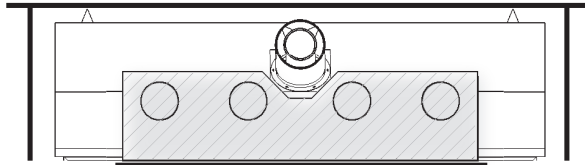

Front wall outlet using LDK1, LDK4 or LDK9

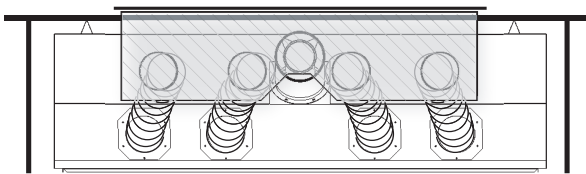

Rear wall outlet using LDK1, LDK4 or LDK9
Note: Fireplace vent may conflict with plenum. Offset vent around plenum.

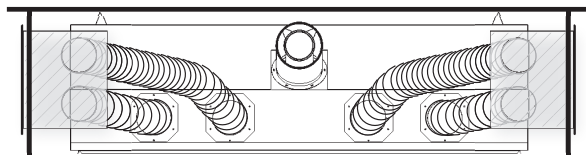

Side wall outlets using LDK3

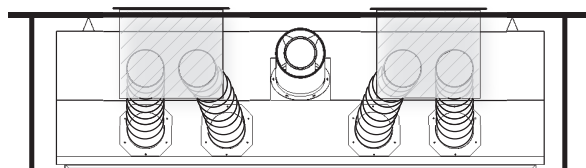

Rear wall outlets using LDK3

Note: Vertical venting straight off 1600K heater will NOT clear 38" (LDK4) or 48" (LDK1) plenums without offsetting vent around plenum.

Note: Take-off collars staggered, 2 per side

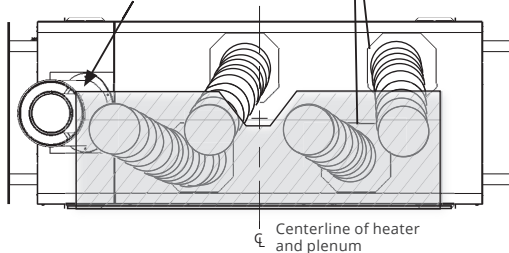

Centerline of heater and plenum

1600K L1 see-thru using LDK1, LDK4 or LDK9

Note - When using LDK7, the discharge opening must be located in the same room as the fireplace.

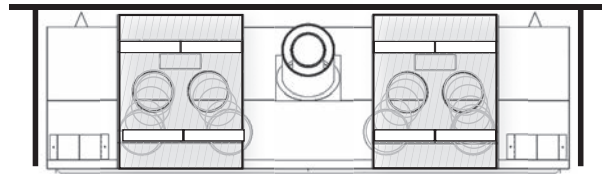

With LDK7

Corner installations

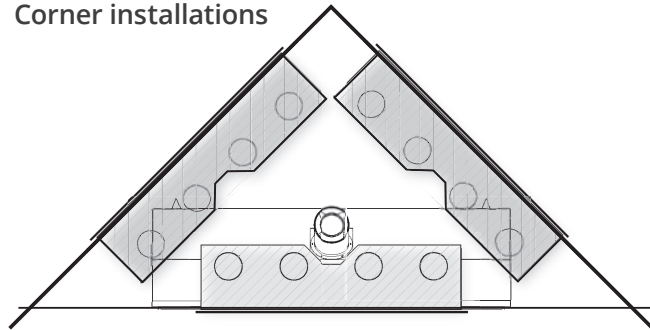

WARNING

The plenum duct kits are approved for horizontal discharge ONLY. The termination duct plates are approved for vertical upward discharge ONLY. DO NOT install plenum or termination plates in floor or ceiling. DO NOT COVER OR PLACE objects in front of or on top of air outlet(s). AVOID locating outlet within 7 feet [2134 mm] of the floor level as discharge air temperatures are hot!

DO NOT DISCHARGE THROUGH EXTERIOR WALLS!

NOTE This duct kit may also be used for outdoor installations where reduced wall surface temperatures above the unit are desired. The discharge grilles must be located under the weatherproof enclosure described in the GV60CKO Outdoor Fireplace Conversion Kit instructions.

Appendix D—HeatShift System

Overview (applies to LKD1, LDK3, LDK4 and LDK9 kits)

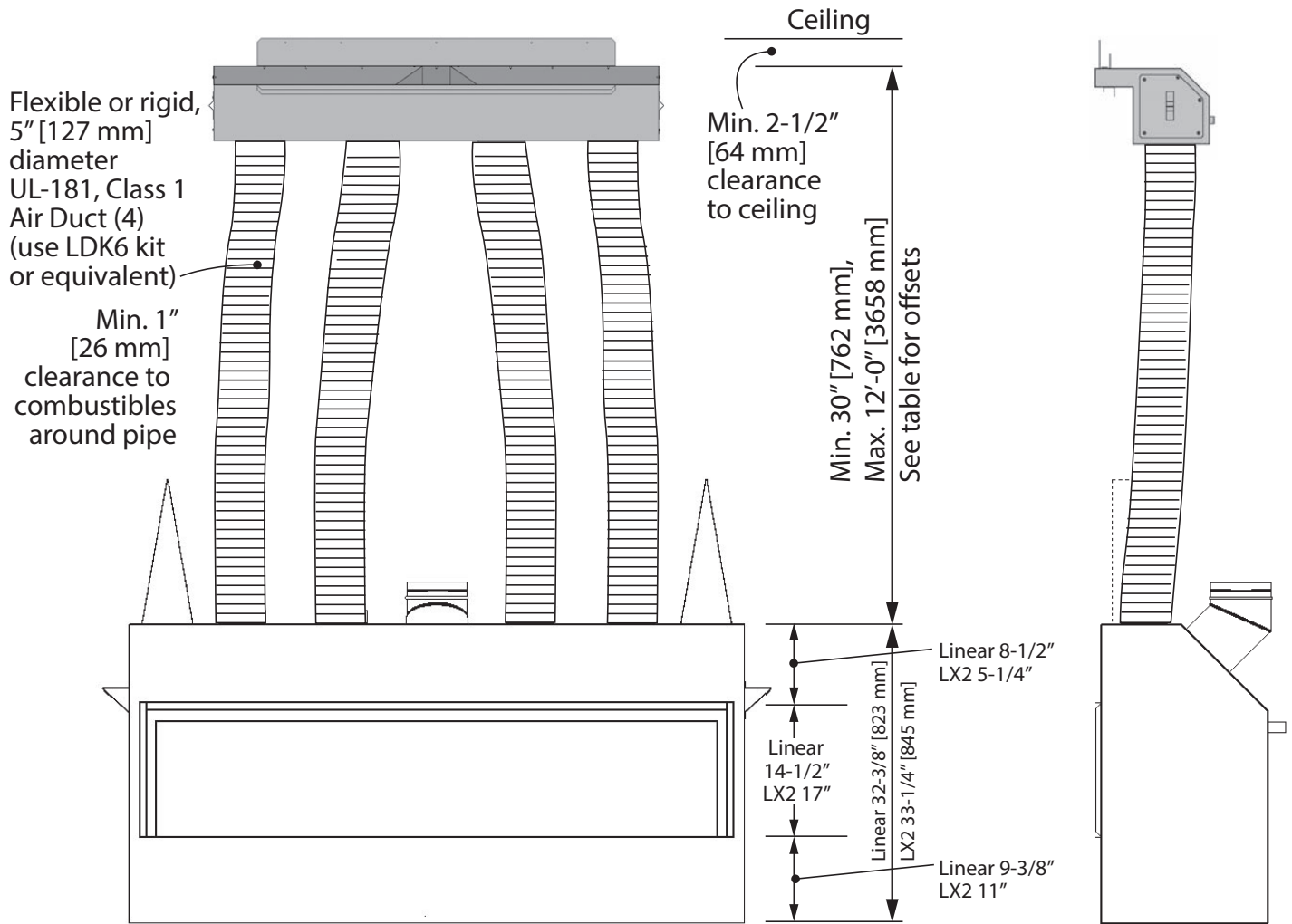

Appendix D—HeatShift System

Overview (applies to LDK7)

NOTE Discharge opening must be located in the same room as fireplace when using LDK7.

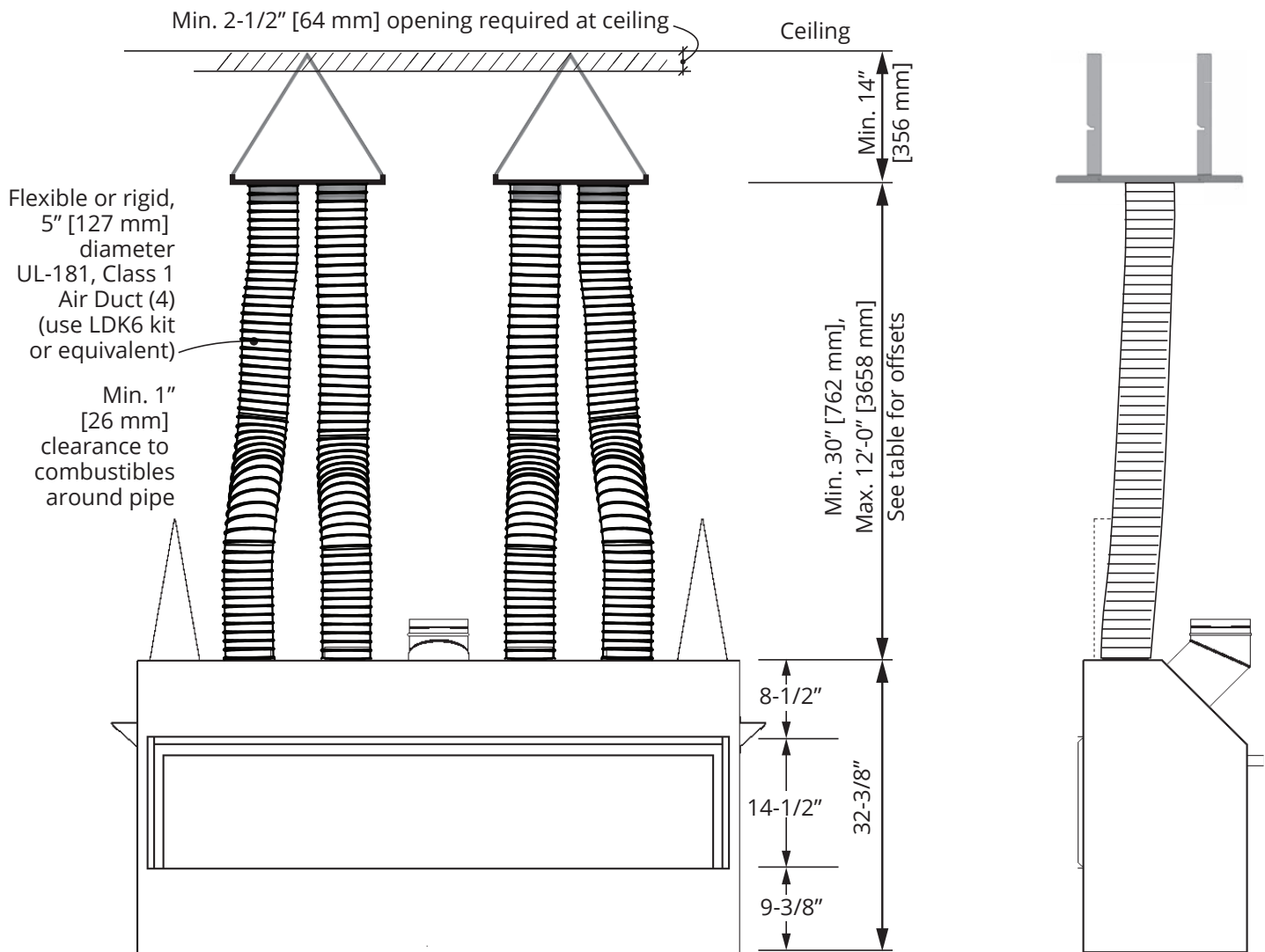

Appendix D—HeatShift System

Y Vertical Rise	X Max. Allowable Horizontal Offset
30" 762 mm	24" 610 mm
36" 914 mm	36" 914 mm
42" 1067 mm	48" 1219 mm
48" 1219 mm	60" 1524 mm
54" 1372 mm	72" 1829 mm
60" 1524 mm	84" 2134 mm
66" 1676 mm	96" 2438 mm
12'-0" 3.7 m	96" Max.

With Plenum

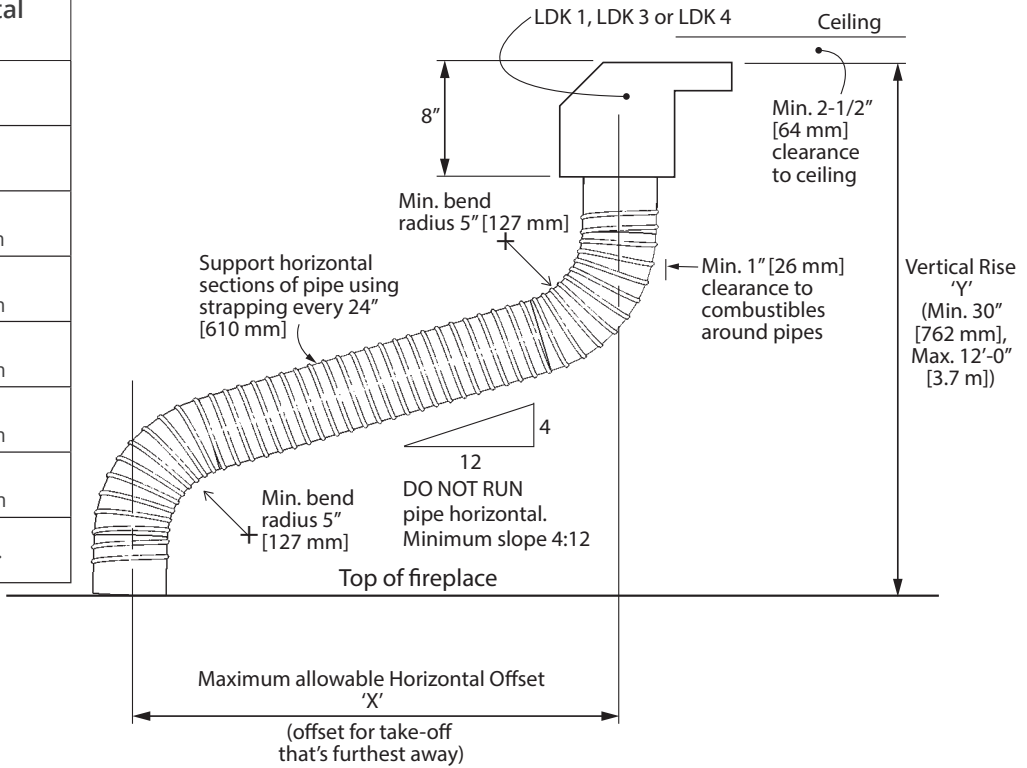

With Plates

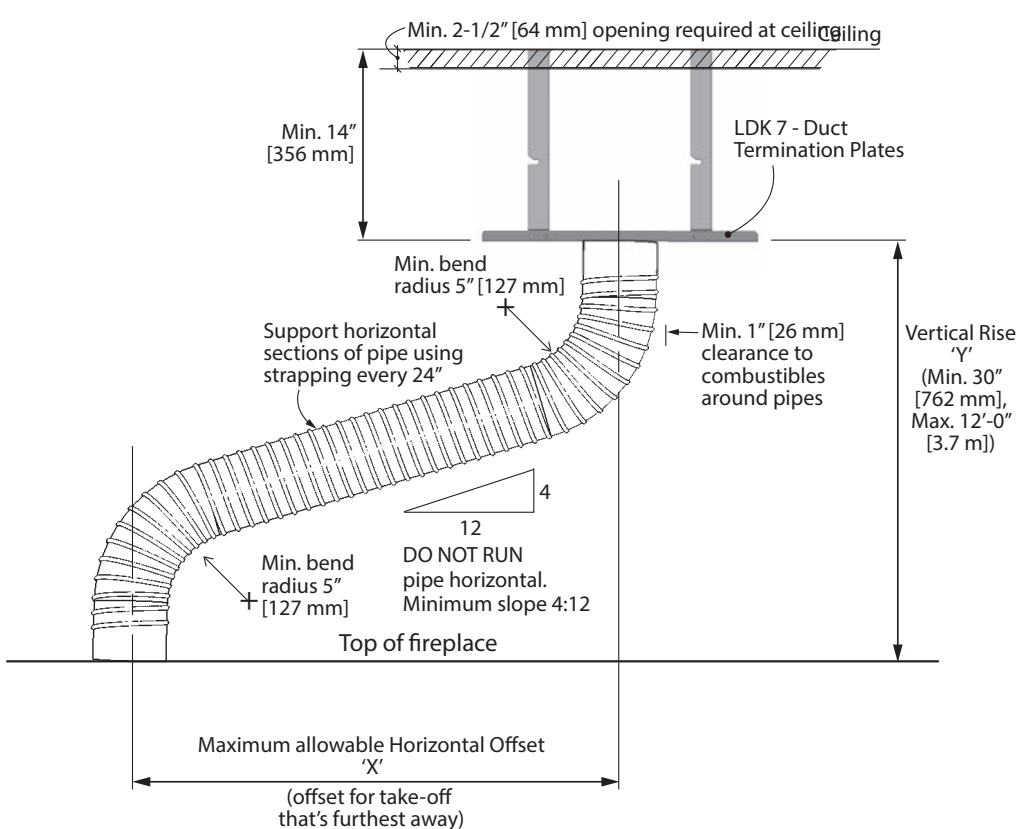

Appendix D—HeatShift System

Plenum Dimensions

LDK 1

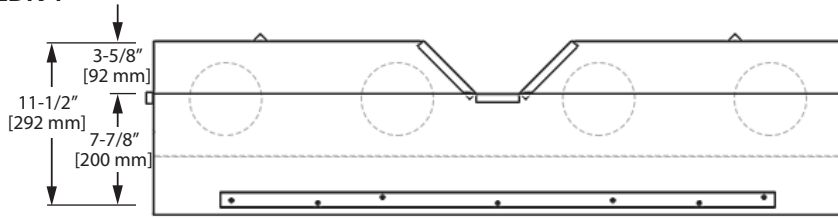

Top View

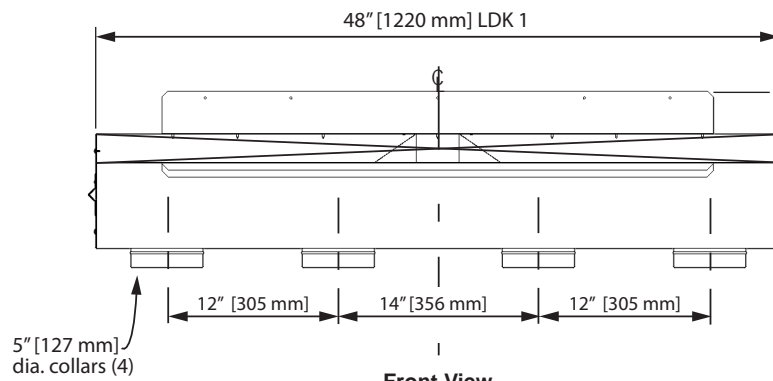

Front View

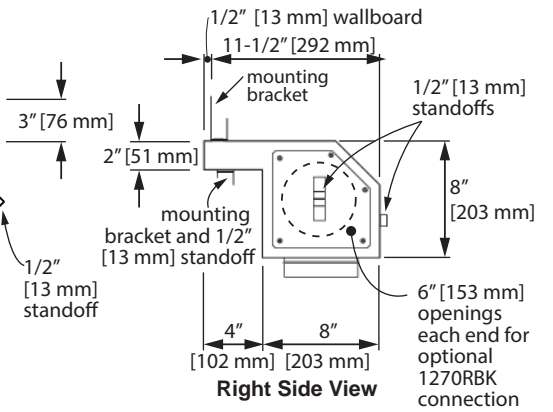

Right Side View

LDK 4

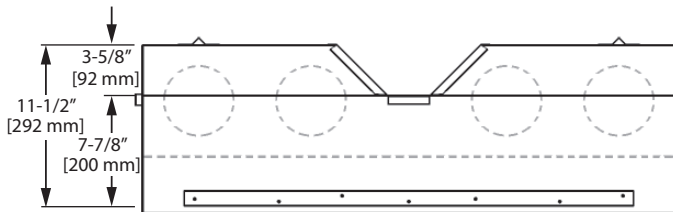

Top View

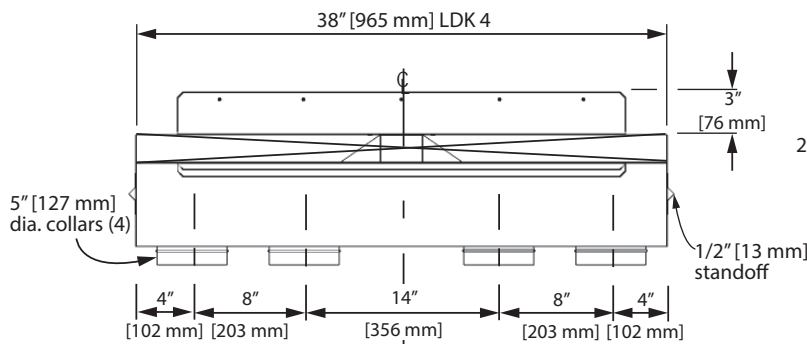

Front View

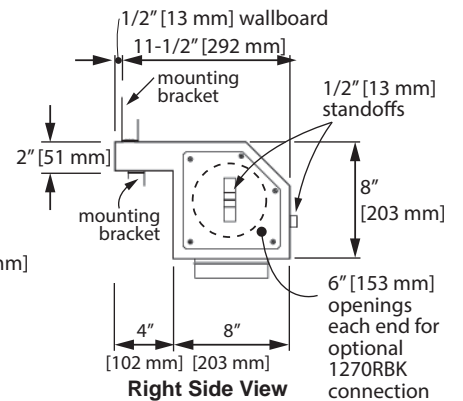

Right Side View

Appendix D—HeatShift System

Plenum Dimensions (cont'd)

LDK 3

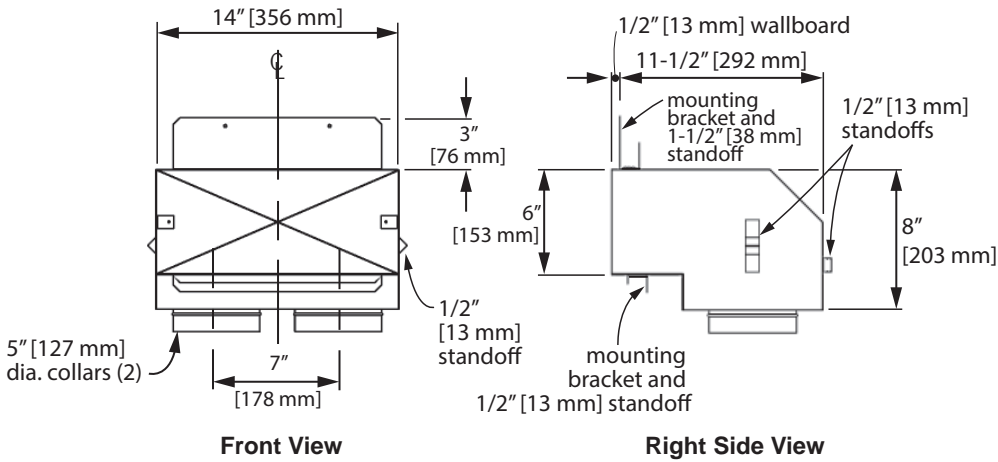

LDK 9

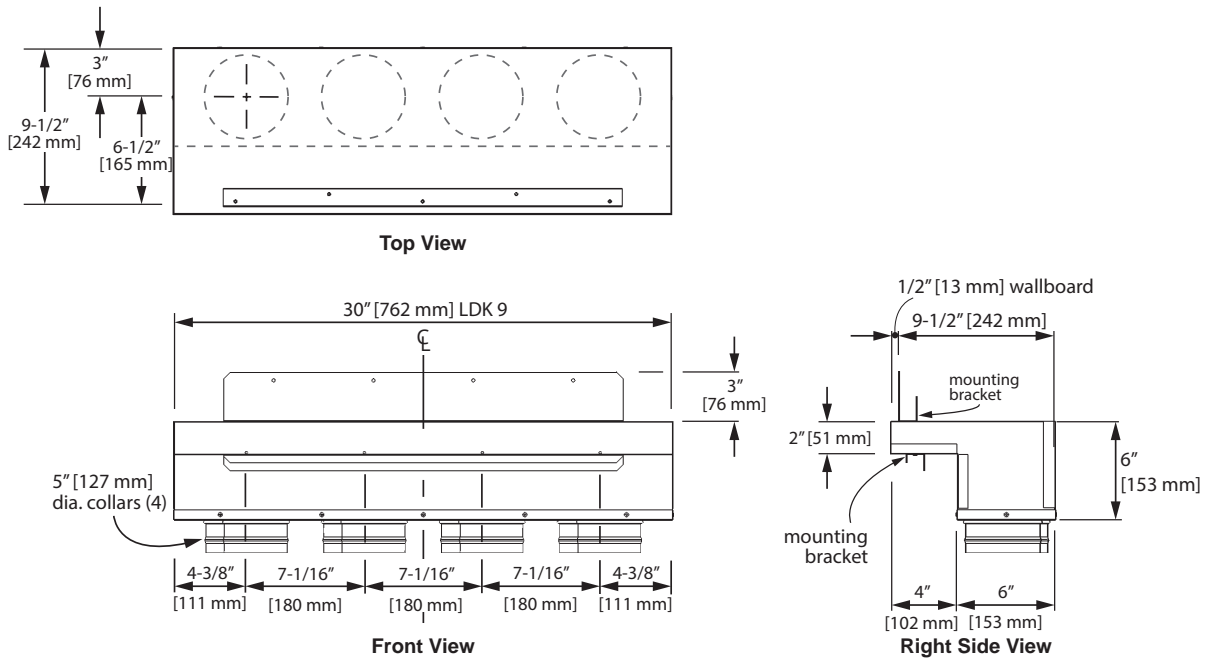

Appendix D—HeatShift System

LDK7 Plates Dimensions

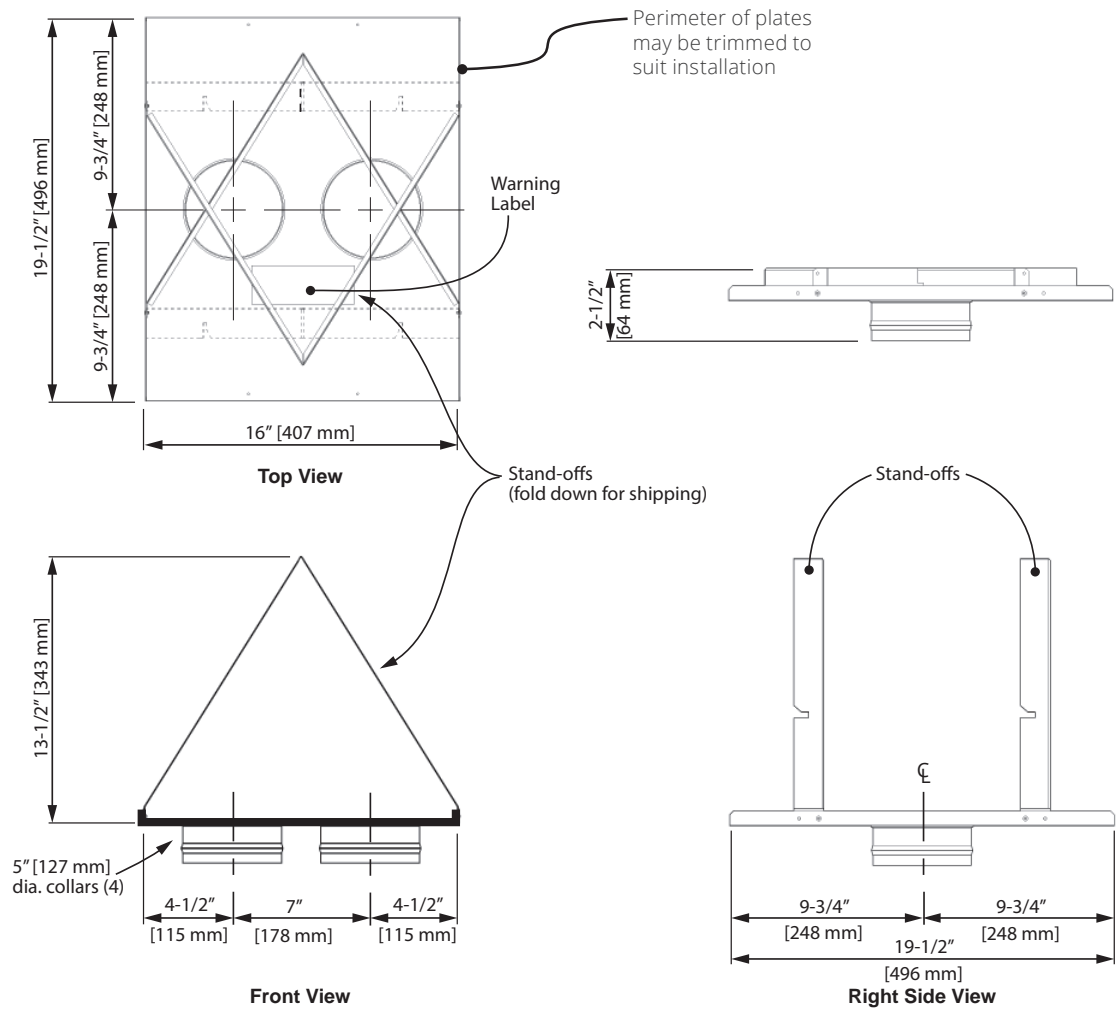

Appendix D—HeatShift System

Rough Frame Openings

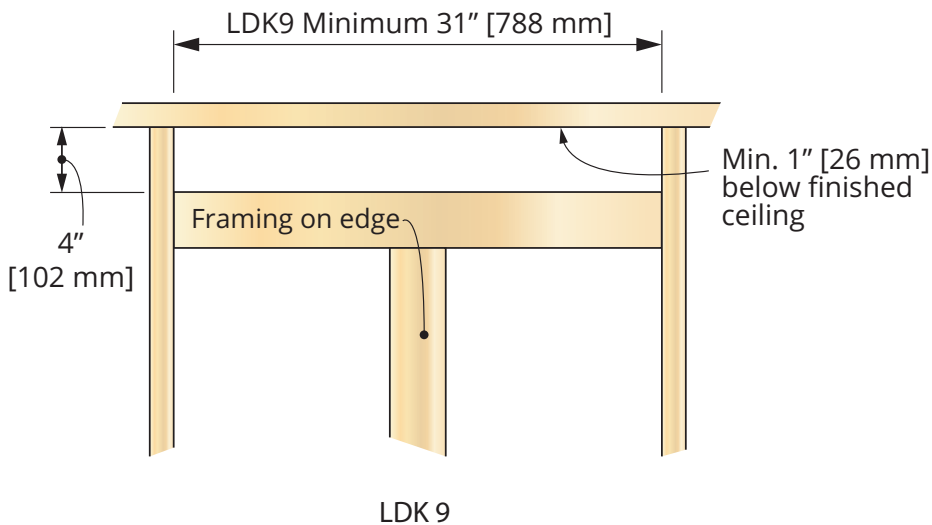
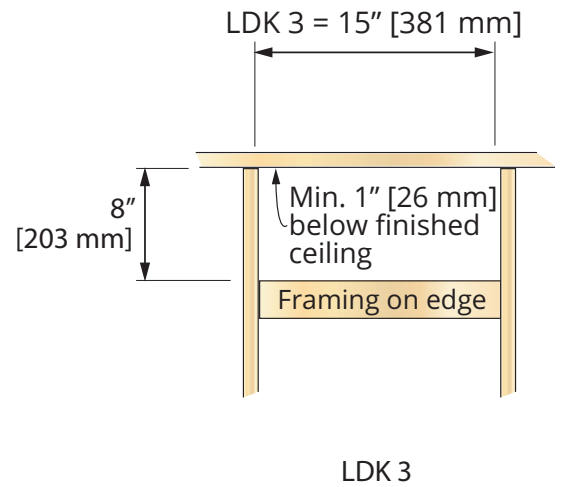
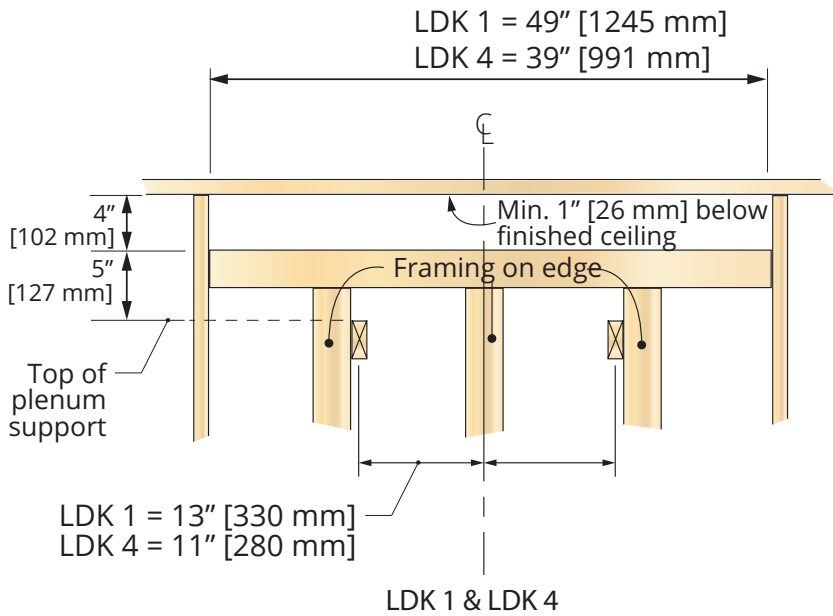

Appendix D—HeatShift System

Framing and Clearances—Plenums, front view

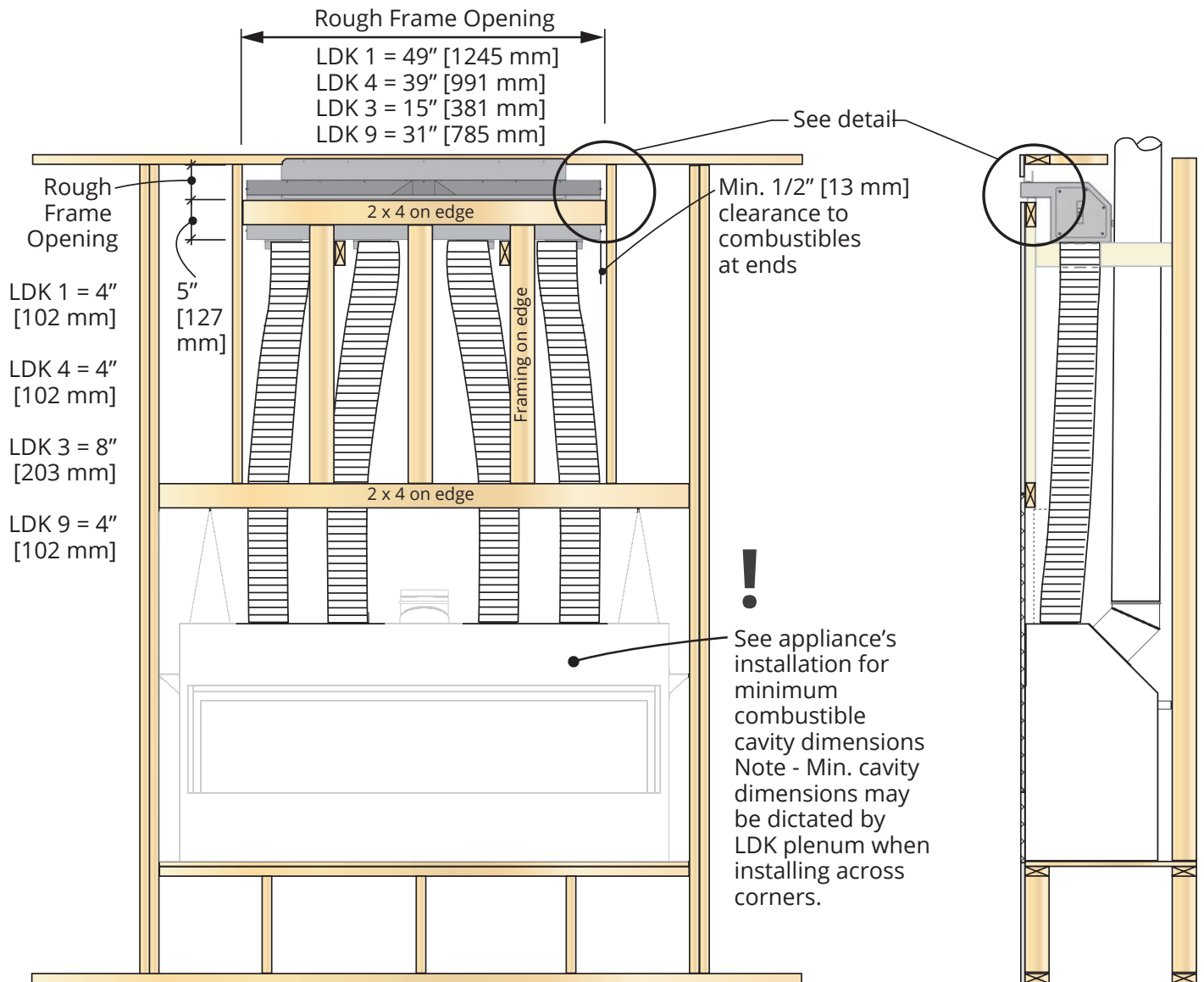

Appendix D—HeatShift System

Framing and Clearances—Plenums, side view

LDK 1 & 4

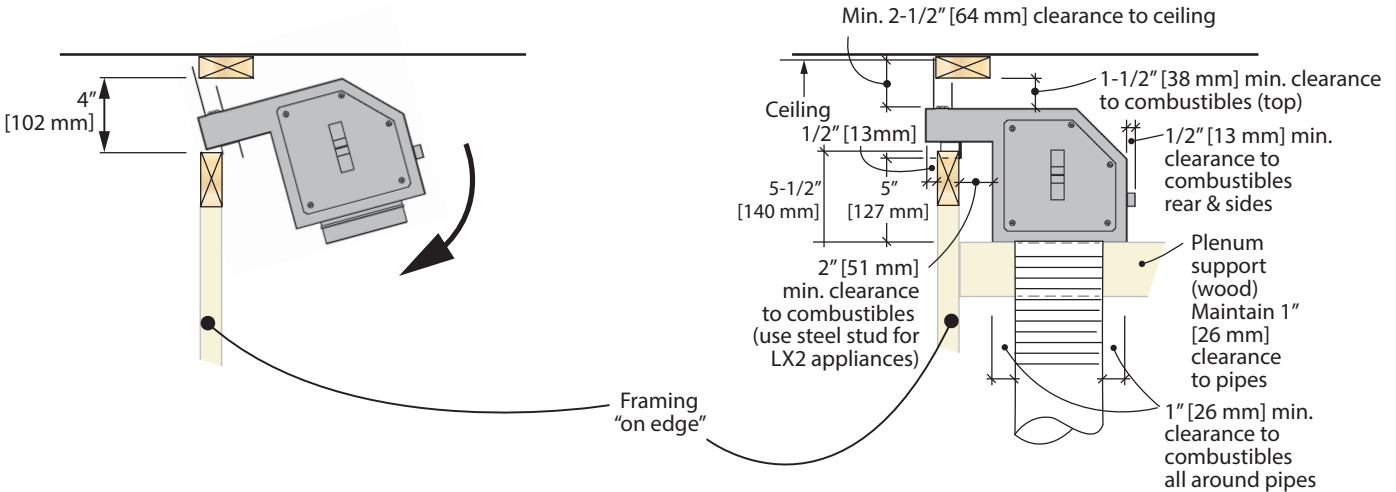

LDK 3

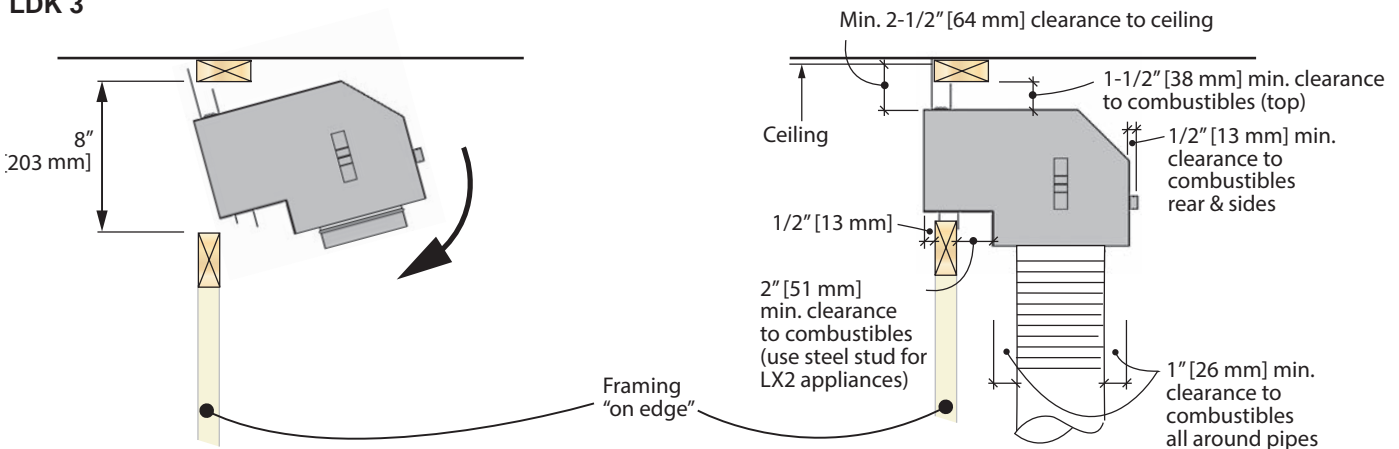

LDK 9

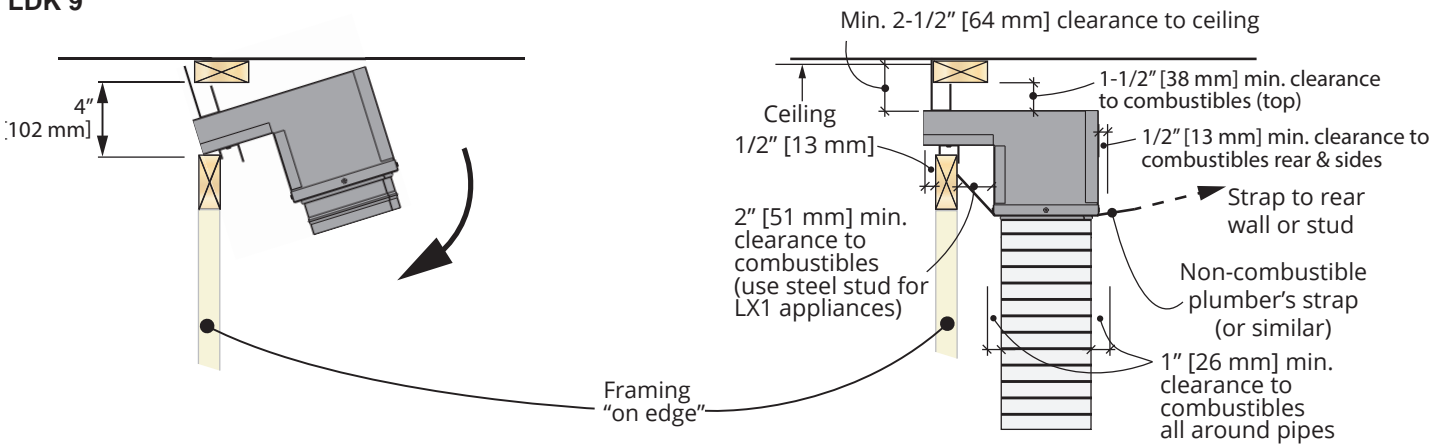

Appendix D—HeatShift System

Wall Valance Discharge Opening using LDK7—Duct Termination Plates

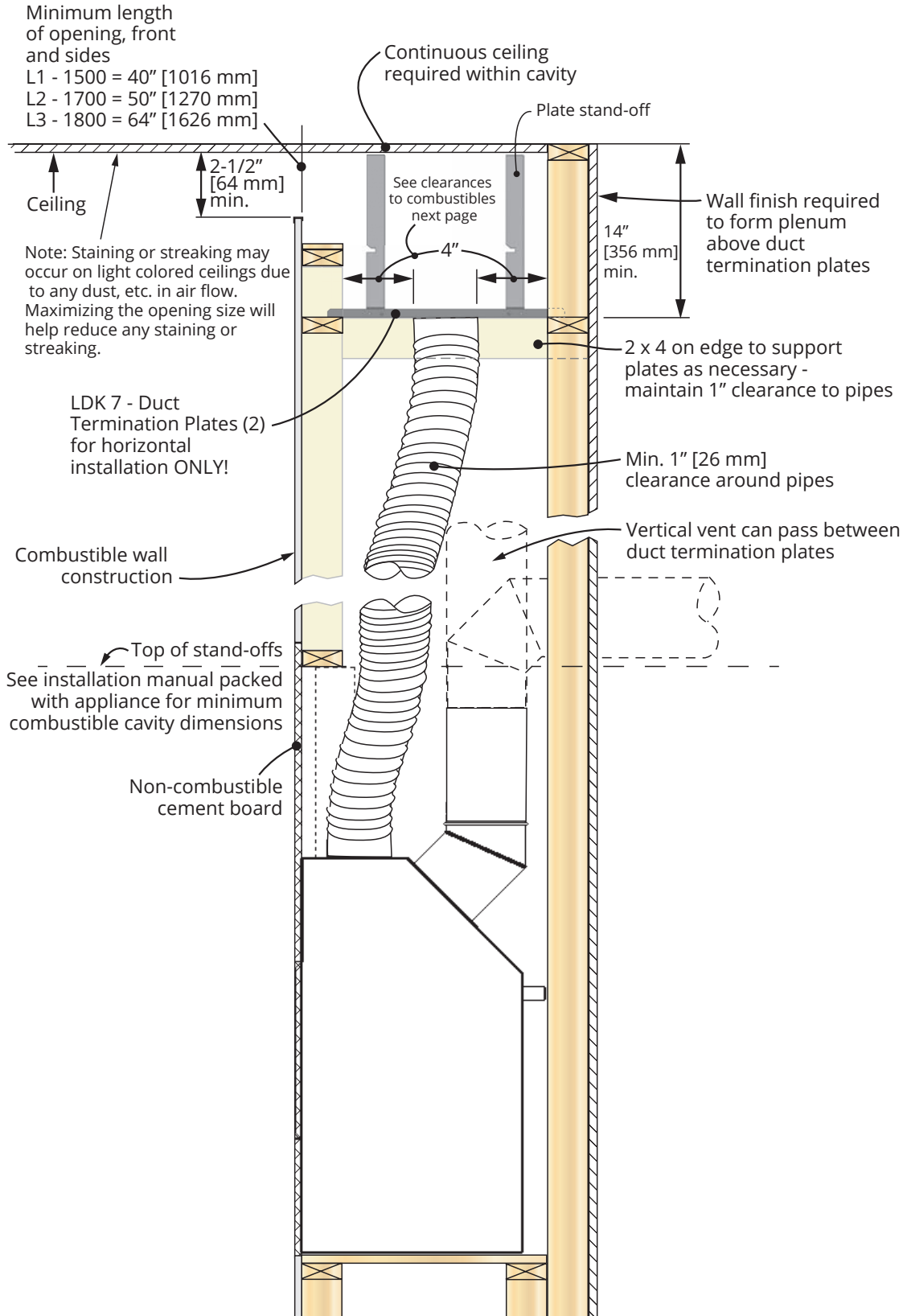

Appendix D—HeatShift System

LDK7 Clearances to Combustibles

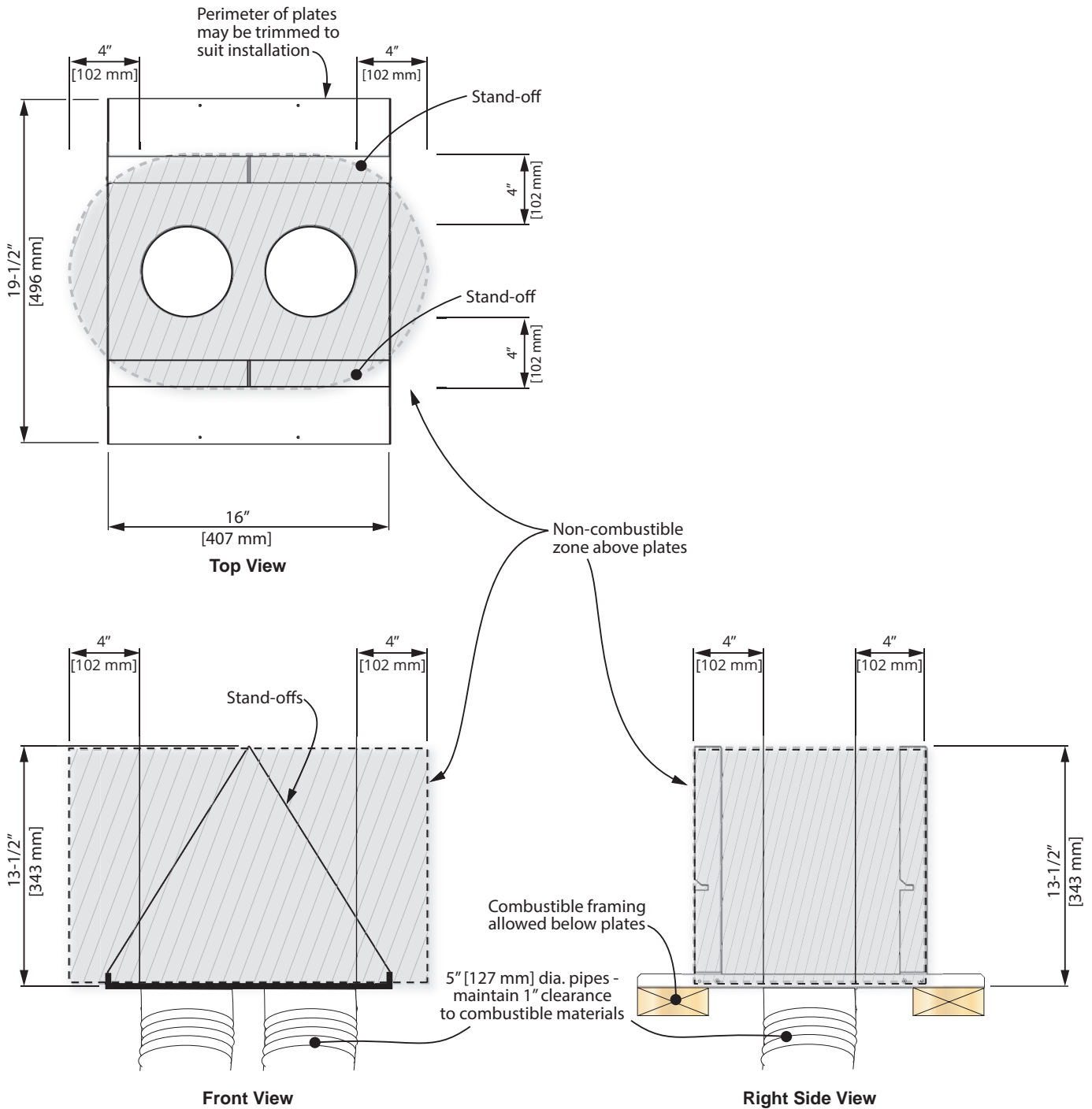

Appendix D—HeatShift System

LDK Duct Kit LDK 1, LDK 4 with optional 1270RBK HeatSplit Remote Blower Kit
(not approved with outdoor installations)

HeatShift™ + HEATSPLIT

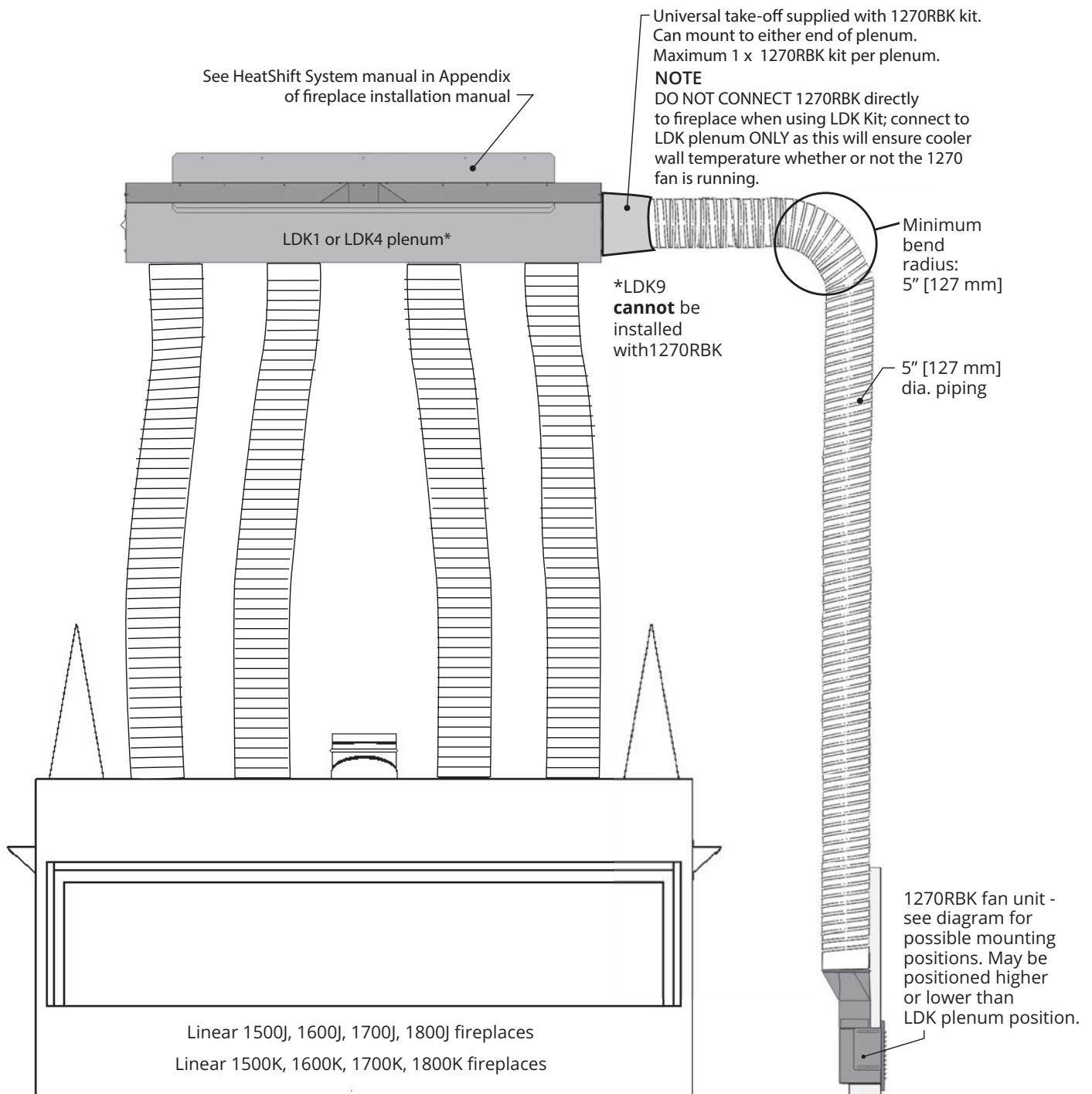

Appendix D—HeatShift System

COMBUSTIBLE Mantel Clearances Linear appliances (when using HeatShift System ONLY)

Sidewall clearances remain as stated in this installation manual.

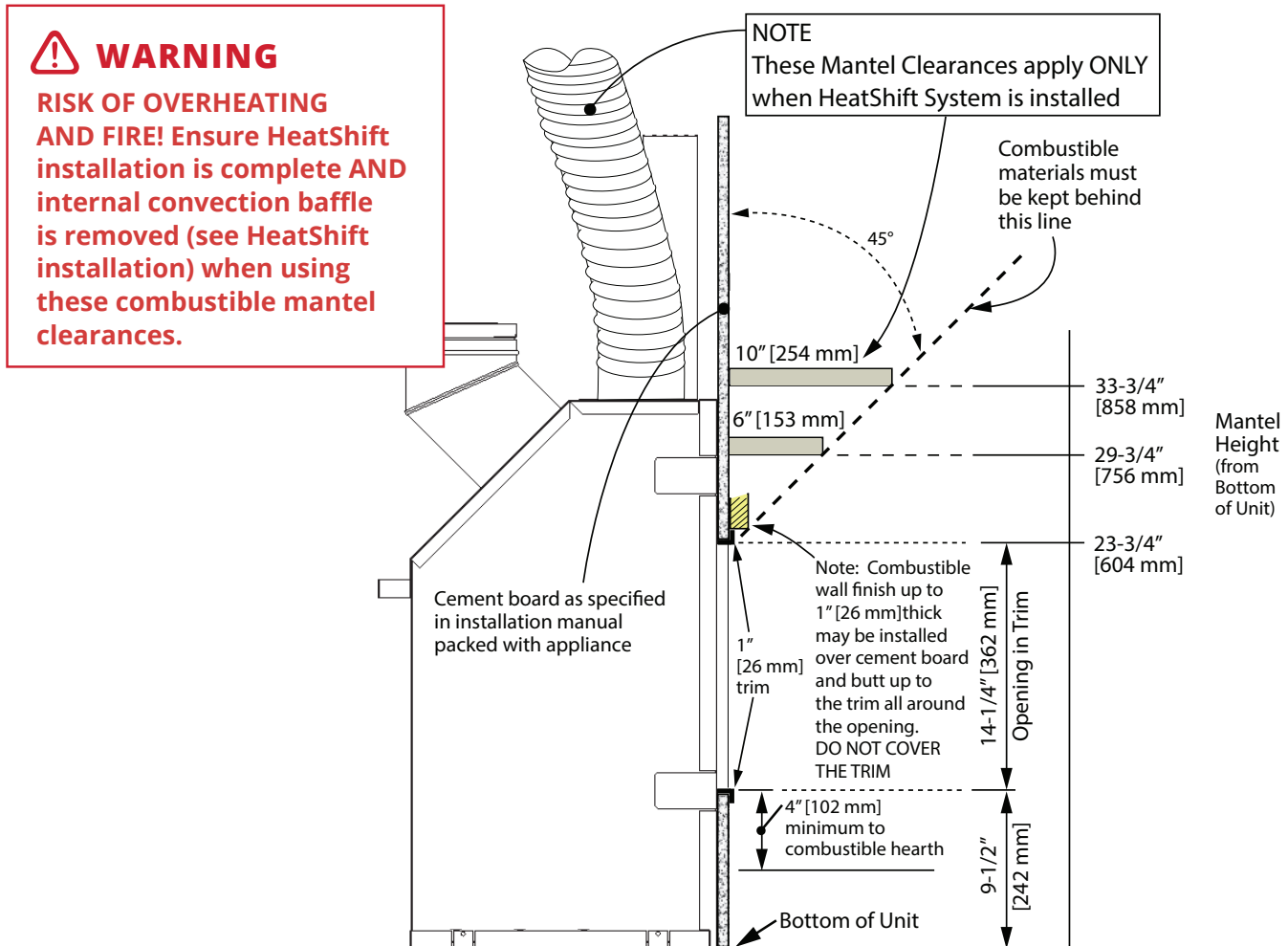

NON-COMBUSTIBLE Flush Hearth/Mantel Projections (when using HeatShift System ONLY)

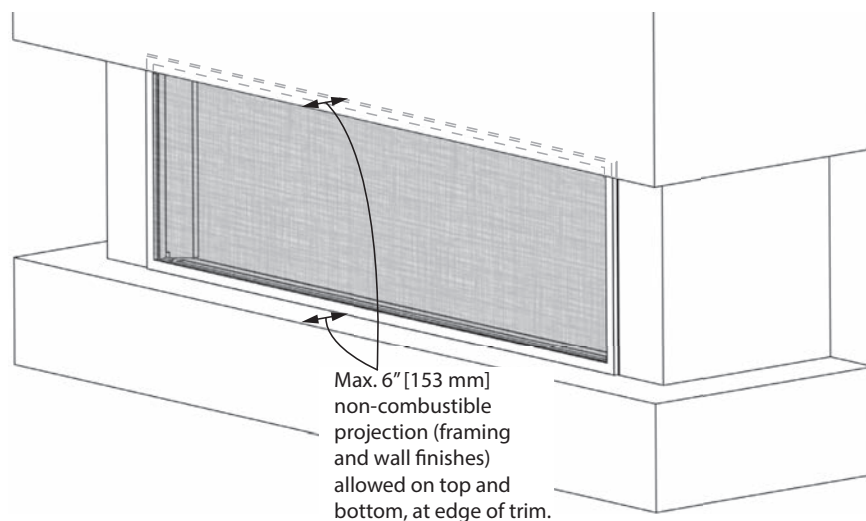

Appendix D—HeatShift System

Remove Convection Baffle

To be effective the LDK Duct Kit requires that a convection baffle located above the firebox inside the appliance case be removed to allow the hot airflow to convect upwards into ducts installed on the fireplace.

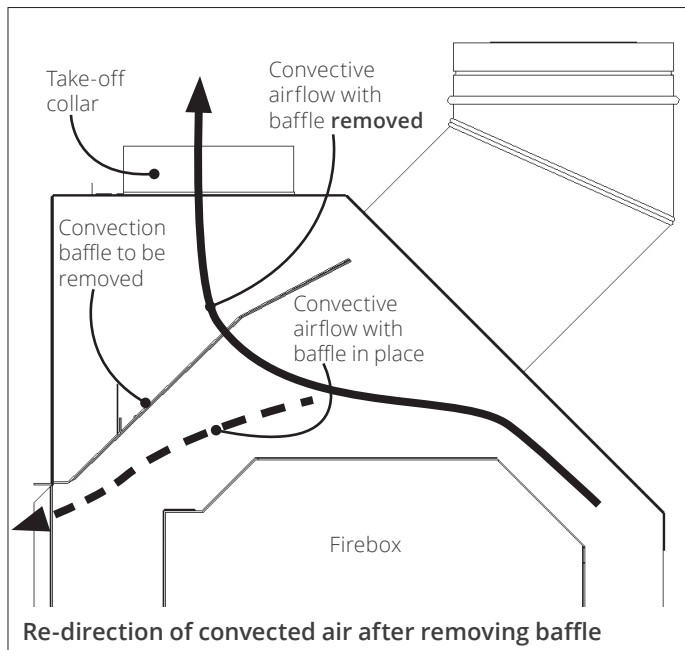

- Remove the convection baffle from the appliance. It is held in place by screws located right behind the upper edge of the fireplace opening (3 screws/baffle). Recycle this panel as it is no longer needed.

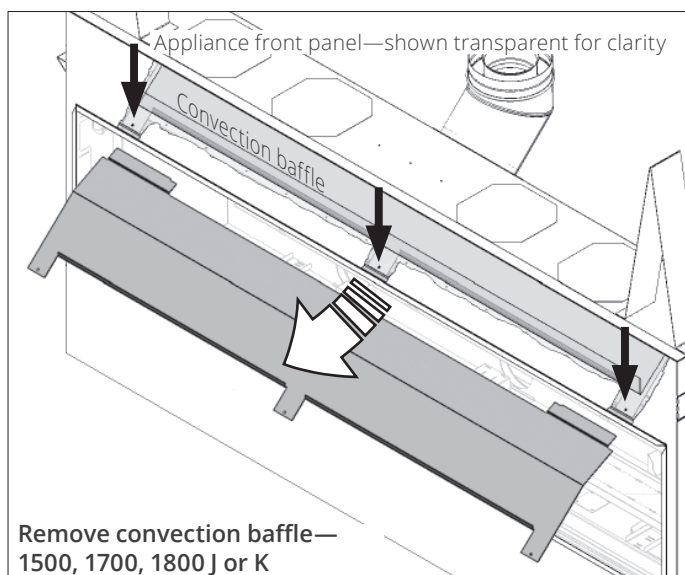

Appendix D—HeatShift System

Install HeatShift collars

1. Remove the four cover plates on top of the appliance case (6 screws each).

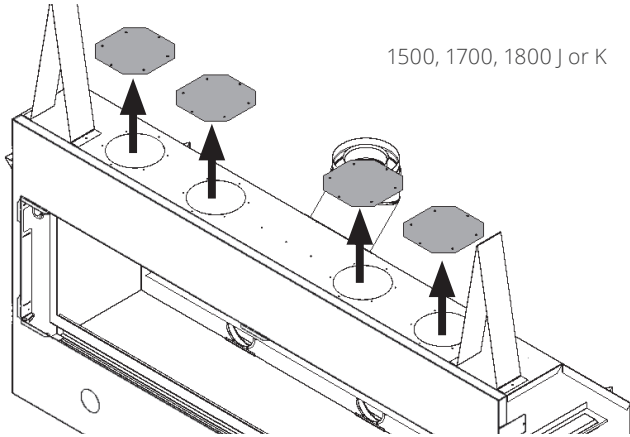

2. Install the collars on the holes on top of the appliance's case (6 screws each).

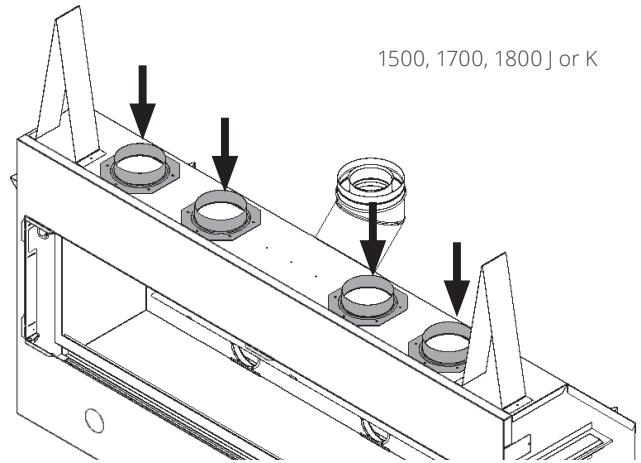

WARNING

All FOUR (4) takeoffs MUST BE CONNECTED TO PLENUM(S).

WARNING

DO NOT INSTALL 1270RBK Remote Blower Kit to any of these 4 takeoffs.

Appendix D—HeatShift System

Install Plenum Kits (LDK1, LDK3, LDK4 & LDK9) —see next page for LDK7 Duct Termination Plates

1. Frame a rough opening at the desired location—see earlier sections of this manual for allowable plenum positions and rough frame opening sizes.
2. Install top mounting bracket(s) to the plenum using screws provided (use the short sheet metal screws provided otherwise the screw tails (ends) will interfere with the finishing frame when installed).

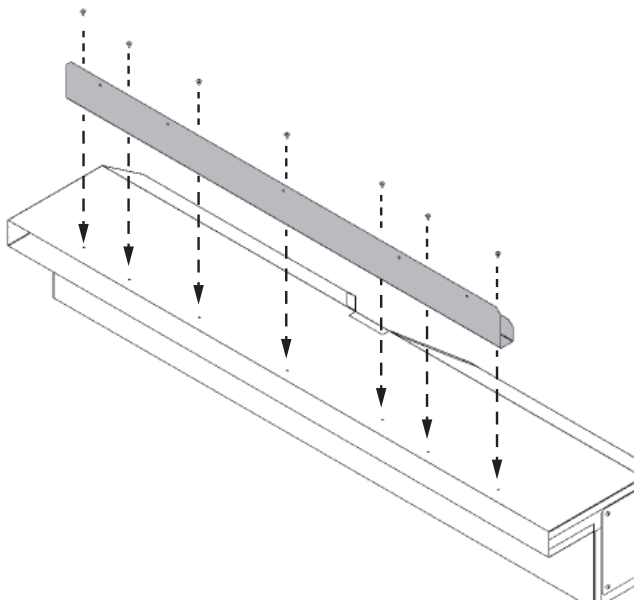

3. Install the plenum(s) into the rough frame opening maintaining minimum clearances to combustibles as listed—see Rough Frame Openings. Fix the plenum to the framing using nails or screws through the top mounting bracket. **Note that the mounting brackets are not intended to carry the weight of the plenum and pipes. Provide support to the underside of the plenum and ensure the plenum is level and its outlet is not distorted—see Framing and Clearances.** Use metal strapping (all-round, not supplied) as required to further secure the plenum to framing.
4. Attach one section of UL-181, Class 1 approved air duct to each of the collars and secure it with gear clamps provided. **DO NOT SPLICE DUCTS!**
5. Attach the top of the pipe sections to the plenum securing them with the gear clamps provided. An upward slope must be maintained in horizontal sections of pipes for proper convection. Use straps as necessary to maintain the pipes positions. Support horizontal sections every 24 inches [610 mm].

6. Paint the inside surfaces of the plenum using high-temperature flat black spray paint for installations where the inside of the plenums may be visible. **Note:** The flanges of the white finishing frame (when used) will insert approximately 1-1/4" [32 mm] into the plenum covering the shiny sheet metal.

Install the finishing frame or louver to the plenum after the wall finish is completed:

LDK1, LDK4, LDK9: Use the LDK2, LDK5 or LDK10 depending of the length of the plenum.

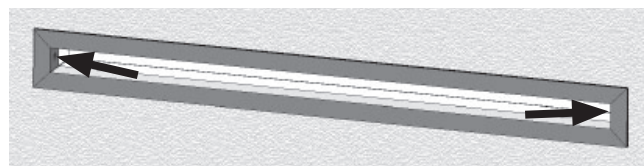

LDK3: Use the grilles provided with the kit.

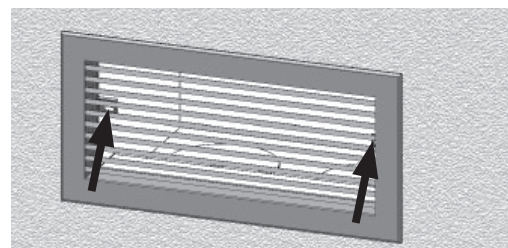

Note: The frame/louver are finished white but may be painted another color if desired; use high temperature paint (250°F/ 121°C). You may also finish up to the perimeter of the plenum opening with your material of choice and not use the frame or louver. Do not finish over any of the opening in the plenum outlet.

7. Continue with the fireplace installation.

Appendix D—HeatShift System

Install Duct Termination Plates (LKD7)

—see previous page for LDK1, LDK3, LDK4 & LDK9 Plenum kits

1. Frame a rough opening and platform at the desired location—see earlier sections of this manual for allowable duct termination plates positions and rough frame opening sizes.
2. On each duct termination plate, rotate both stand-offs to the vertical position and secure in place using screws provided.

2 stand-offs per plate

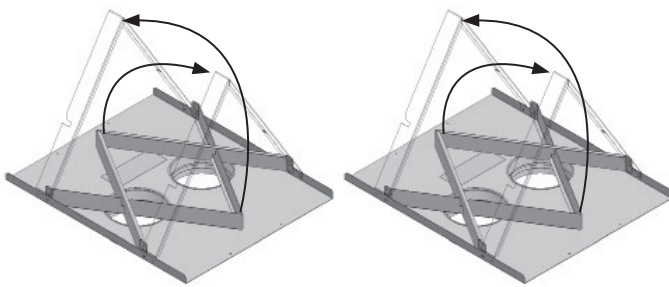

3. Install the termination plates into the framing ensuring collars/pipes on underside of plates maintain 1 inch [26 mm] clearance to combustibles and clearance to combustible above the plates are maintained as listed in Wall Valence Discharge Opening. The termination plates perimeter may be trimmed as necessary to accommodate framing. Secure the termination plate to framing using screws or nails to avoid movement.
4. Attach one section of UL-181, Class 1 approved air duct to each of the collars and secure it with gear clamps provided. **DO NOT SPLICE DUCTS!**
5. Attach the top of the pipe sections to the duct termination plates securing them with the gear clamps provided. An upward slope must be maintained in horizontal sections of pipes for proper convection. Use straps as necessary to maintain the pipes positions. Support horizontal sections every 24 inches [610 mm].
6. Continue with the fireplace installation.

Repair Parts List

	Description	Part no.
LDK1	48" Quad Hot Air Plenum Kit [1220 mm]	
	48" x 2" quad plenum [1220 x 51 mm]	4005476
	5" take-off collars (4) [127 mm]	4005478
	Top mounting bracket/standoffs	4007211
	#8 slotted drive screws 1/4" (7) [6 mm]	798601
LDK2	48" Outlet Frame Kit for LDK1 [1220 mm]	
	Aux Frame-SPL 48" x 2" white [1220 x 51 mm]	4005612
LDK3	14" Double Hot Air Plenums Kit [356 mm]	
	14" x 6" double plenums (2) [356 x 153 mm]	4005464
	5" take-off collars (4) [127 mm]	4005478
	DABL-00-C-SPL 14" x 6" Grilles white (2) [356 x 153 mm]	4005614
	Top mounting bracket/standoffs (2)	4005566
	#8 slotted drive screws 1/4" (6) [6 mm]	798601
LDK4	38" Quad Hot Air Plenum Kit [965 mm]	
	38" x 2" quad plenum [965 x 51 mm]	4005477
	5" take-off collars (4) [127 mm]	4005478
	Top mounting bracket/standoffs	4007213
	#8 slotted drive screws 1/4" (7) [6 mm]	798601
LDK5	38" Outlet Frame Kit for LDK4 [965 mm]	
	Aux Frame-SPL 38" x 2" white [965 x 51 mm]	4005613
LDK6	5" Aluminum 2-ply Flex Kit [127 mm]	
	5" dia 10' (uncompressed) aluminum chimney liners (2) [127 mm x 3 m]	4005635
	4.5" - 6.5" ss gear clamps (8) [114 - 165 mm]	4005642
LDK7	Duct Termination Plates	
	Plate and collar assembly (2)	4006747
	5" take-off collars (4) [127 mm]	4005478
	Screws 8 x 3/8 tap PN HD PH (12)	100A757
LDK9	30" Quad Hot Air Plenum Kit [762 mm]	
	30" x 2" quad plenum [762 x 51 mm]	4007903
	5" take-off collars (4) [127 mm]	4005478
	Top mounting bracket/standoff	4007601
	#8 slotted drive screws 1/4" (5) [6 mm]	798601
LDK10	30" Outlet Frame Kit for LDK9 [762 mm]	
	Aux Frame-SPL 30" x 2" white [762 x 51 mm]	4007951

Each LDK kit is sold separately.

Appendix E—Spare Parts

	Description	Part No.
1	45 degrees flanged elbow	4000945M
2	Elbow gasket	4002999
3	Top stand-offs (2)	4005410
4	Restrictor plate	4003017
5	Cover plates (4)	4005409
6	Take-off cover (2)	4003046
7	Liner panels anchors (2)	4001283
8	LH Window latch assembly	4002770
9	RH Window latch assembly	4002766
10	Convection baffle	4005398
11	Fan screw access plate	4005578
12	Carrying handle/standoff (2)	4005509
13	Bracket - stiffener	4007949
14	Bracket - support	4007950
15	Window assembly	4004743
16	Hot glass warning plate	4003093
17	Burner rail assembly	4007919
18	Burner support bracket	4005428
19	Platform support (2)	4002908
20	Burner end location bracket	4002903
21	Burner support bracket	4007819
22	Middle support (2)	4004974
23	Snap-in receptacle	4006368
24	Inner electrical cover	4007971
25	Electrical box	4007970
26	Outer electrical cover	4007973
27	Cable clamp	4006548
28	Burner module assembly (natural gas)	4007077S
	Burner module assembly (propane gas)	4007737S
29	Pilot shield	4003018AH
30	Pilot assembly (natural gas)	4007880S
	Pilot assembly (propane gas)	4007881S
31	Plug pilot	4000726
33	Thermocouple	4004801
34	Pilot injector #51 (natural gas)	4000735
	Pilot injector #30 (propane gas)	4000736
35	Pilot tube	4000732
36	Pilot hood 2-flame	4000730
37	Extended nut	4001855
38	Electrode	4001856
39	Pilot gaskets (2)	4000715
40	Pilot stand	4006907
41	Burner mounting bracket A	4006918
42	Burner mounting bracket C	4007223

	Description	Part No.
43	L3 Air shutter stopper	4008078
44	Injector/Burner mount	4007702
45	Gas orifice DMS #30 (natural gas)	4007000-30
	Gas orifice DMS#48 (propane gas)	4007000-48
46	Air shutter	4007748
47	Brass socket pipe plug	4008003
48	Burner module plate	4007076
49	Gaskets module plate, short (2)	4004749
50	Gaskets module plate, long (2)	3000400
51	Air shutter lever	4007225
52	#10 * 1/2 Flat washers (2)	4006692
53	3/16" * 9/16" Spring washers (2)	4006691
54	#10-24 Zinc finish steel reverse nuts (2)	4007890
55	Gas supply pipe assembly	4007089
56	Block/pipe connector	4006689
57	Valve mount	4002905
58	GV60 valve, no connector	4000873
58a	By-pass screw #260 (natural gas)	4005442
	By-pass screw #160 (propane gas)	4000810
58b	Straight connector	220K891
58c	Inlet elbow 1/2" tube x 3/8"	4002909
59	Pilot Compression Fitting	220K913
59a	Nut M8X1	720A199
60	Thermocouple interrupter	4001037
61	Pipe s/s flex	4000345
62	Receiver Valor 10 Two Way	4005597
63	Wire harness GV60	4001187
64	Yellow cable to interrupter	4002096
65	Red cable to interrupter	4001035
66	Ignition cable sleeve	4002244
67	Ignition cable 900 mm	4004800
68	Valor 10 handset wall holder	4004459
69	Valor 10 button handset black	4007548
70	Remote battery & Wall switch kit	RBWSK
71	Junction box	4005527
72	Cover plate & 4 screws	4005526
73	Battery holder	4006553
74	Cable tie	4005524
75	Harness assembly	4005523
76	Plate with magnets	4005391
77	Long screws (2)	4001444
78	Wall switch with 2 screws	4005522
79	Battery cover assembly	4005390

Appendix E—Spare Parts

	Description	Part No.
80	GV60 Valve Repair Kit	4004544
81	Liner panels - complete set	
	Fluted Black Liners	1815FBL
	Plain Black Liners	1860PBL
	Reflective Glass Liners	1825RGL
82	Retainer clip hardware (for 1825RGL kit only)	1725RGL-3
83	Top panel	
	Black (2)	4006286
	Black (2)	4006286
	Black (2)	4006286
84	Rear panel	
	Fluted Black - sides (2)	4005107
	Fluted Black - center	4005106
	Plain Black - sides (2)	4008536
	Plain Black - center	4008537
	Reflective Glass (3)	4005121
85	LH side panel	
	Fluted Black	4003071
	Plain Black	4003071
	Reflective Glass	4004273
86	RH side panel	
	Fluted Black	4003072
	Plain Black	4003072
	Reflective Glass	4004274
93	Murano Glass Fire	1800DGMV2
94	Glass panel A	4007487
95	Glass panel B	4007488
96	Glass panel C	4007489
97	Glass panel D	4007490
98	Glass panel E	4007491
99	Glass panel F	4007492
100a	Runner assembly	4010808
100b	Runner assembly	4010809
100c	Runner assembly	4010811
100d	Runner assembly	4010810
101	Cross runner	4007482AH
102	1/2" clear fireglass bag (2)	4004521
103	Birch Log Kit	1800BLK
104	Birch Log L1	4007371
105	Birch Log L2	4007372
106	Birch Log L3	4007373
107	Birch Log L4	4007374
108	Birch Log L5	4007375
109	Birch Log L6	4007376
110	Birch Log L7	4007377

	Description	Part No.
111	Birch Log L8	4007378
112	Birch Log L9	4007379
113	Birch Log L10	4007380
114	Birch Log L11	4007381
115	Birch Log L12	4007382
116	Mixed grey embers (10 cup bag)	4008047
117	Splinters grey (bag)	4005813
118	Right hand platform	4004955AH
119	Left hand platform	4004956AH
120	Driftwood Kit	1805DWKV2
121	Driftwood Log L15	4007985
122	Driftwood Log L16	4007986
123	Driftwood Log L17	4007987
124	Driftwood Log L18	4007988
125	Driftwood Log L19	4007989
126	Driftwood Log L20	4007990
127	Driftwood Log L21	4007991
128	Driftwood Log L22	4007992
129	Brown beach pebble (1)	4003082
130	Grey beach pebble (2)	4003083
131	White beach pebble (2)	4003084
132	Black beach pebble (2)	4003085
133	Small grey beach pebble (1)	4003086
134	Beige beach pebble (2)	4003087
135	Vermiculite bag (2)	4002940
136	Right hand platform	4004955AH
137	Left hand platform	4004956AH
138	Splitwood Kit	1800SWK
139	Splitwood log 2	4006123
140	Splitwood log 3	4006124
141	Splitwood log 5	4006126
142	Splitwood log 7	4006128
143	Splitwood log 9	4006130
144	Splitwood log 11	4006132
145	Splitwood log 12	4006678
146	Splitwood log 13	4006679
147	Splitwood log 14	4006680
148	Splitwood log 15	4006681
149	Splitwood log 16	4006682
150	Splitwood log 17	4006695
151	Coal ember bag (4)	4001843
152	Splinters grey, bagged (1)	4005813
153	Right hand platform	4004955AH
154	Left hand platform	4004956AH

Appendix E—Spare Parts

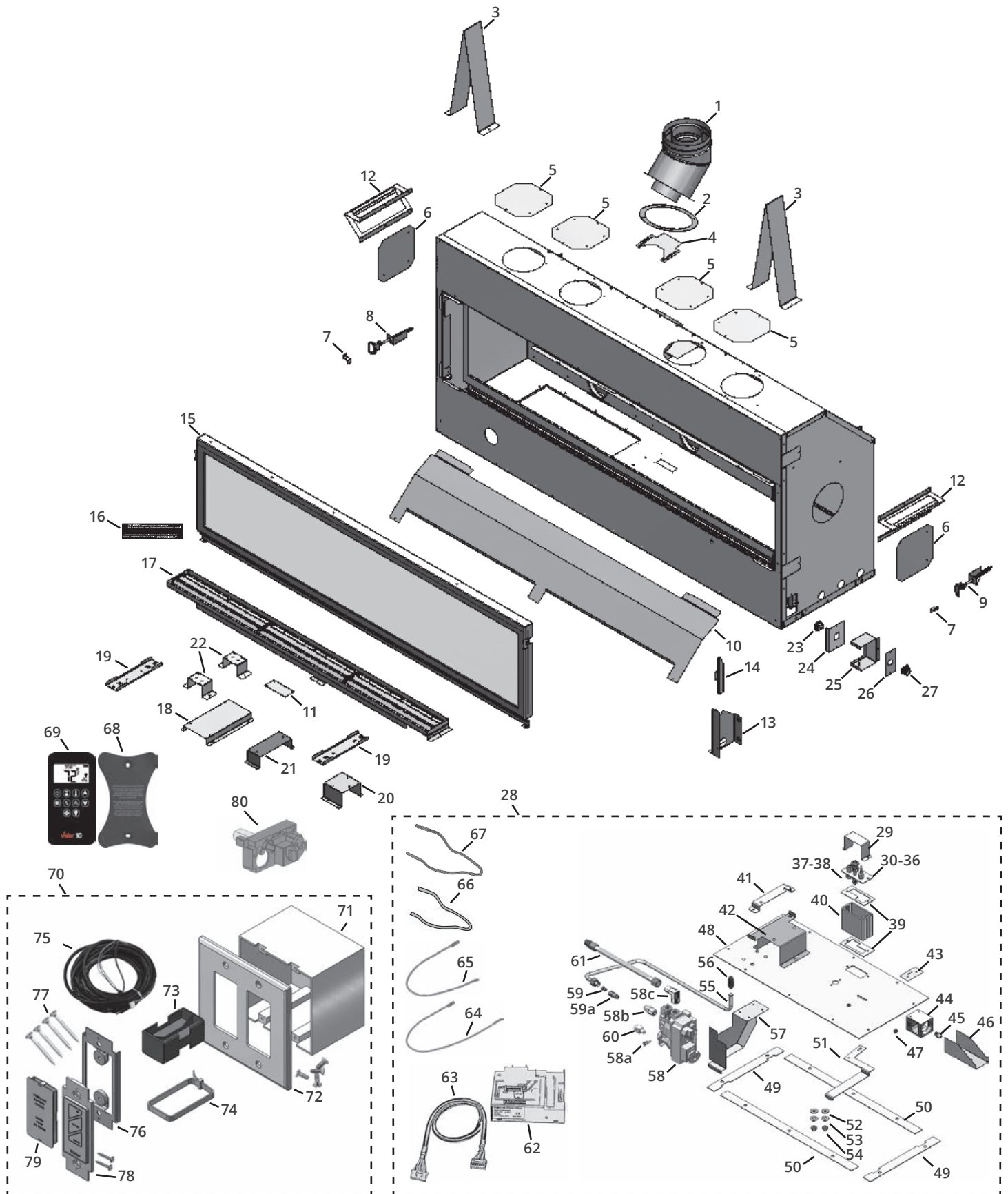

Appendix E—Spare Parts

